



Reservedeler katalog GS15
Spare part catalogue GS15
Listino ricambi GS15
Ersatzteil Liste GS15



Hummelfjellveien 27
2550 Os - Østerdalen
Phone +47 62 20 20 60
E mail: post@mekanor.no

Version 2 - 2012



The blue line.....join us

BASIC FRAME

GS15 - GS20

26 - 09 - 2011

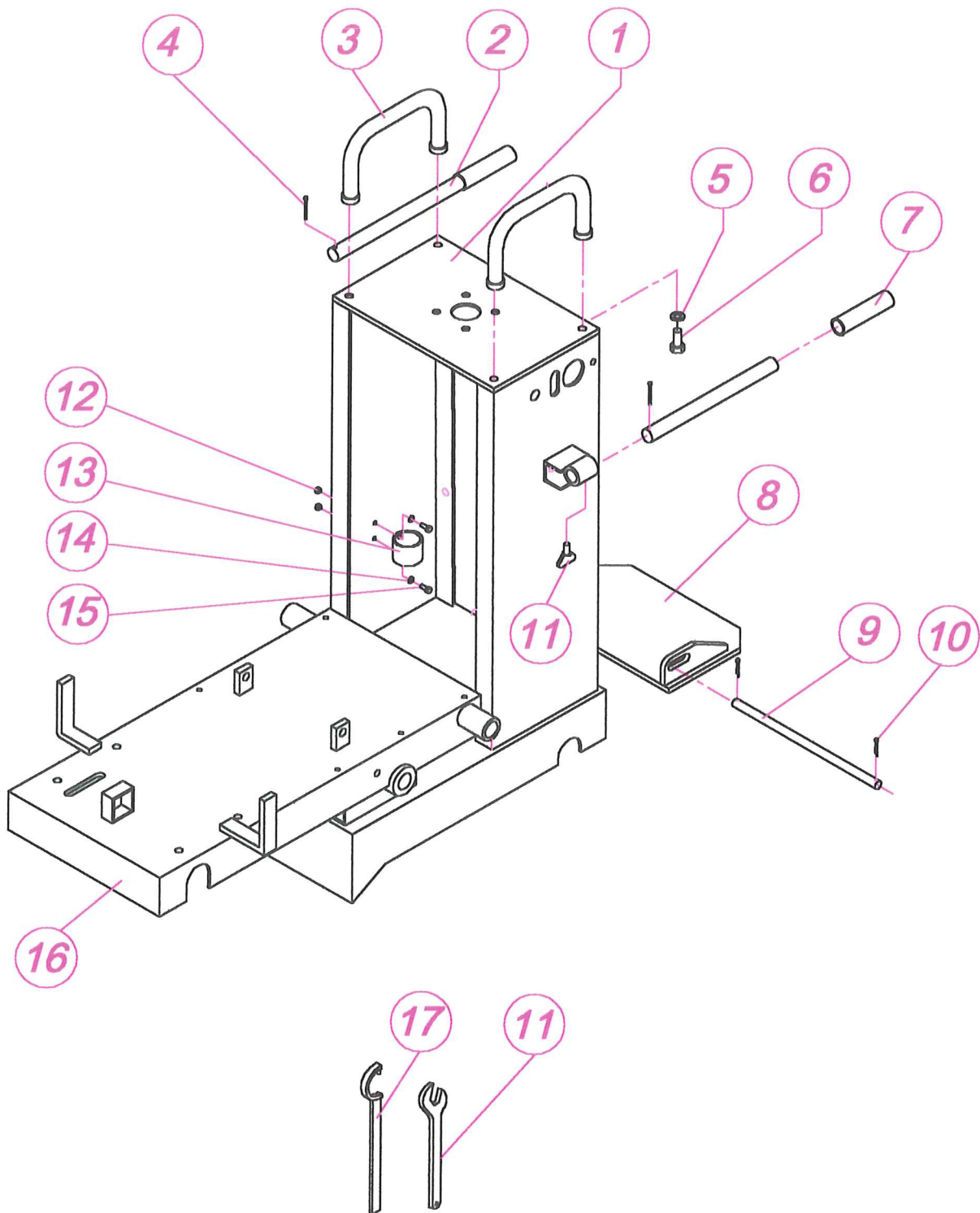



Basic frame

GS15 GS20

115 202

Ref.no	Part.no	Description	Data	Qty
1	115 389	Basic frame GS15 - GS20		1
2	115 188	Extension steering handle with grip	Ø25	2
3	115 187	Lift and protection handle	Ø25	2
4	850 101	Split pin		2
5	850 056	Spring washer	M12	4
6	850 015	Screw	M12x30	4
7	810 001	Rubber hand grip	Ø25	2
8	115 040	Step plate		1
9	115 041	Pin for step plate	Ø15	1
10	850 101	Splitt pin		2
11	810 061	Wrench	36m.m	1
12	850 073	Nut	M6	2
13	115 048	Tool dispenser		1
14	850 045	Washer	M6x16	2
15	850 002	Screw	M6x16	2
16	116 079	Movable frame	GS15/20	1
17	115 184	C wrench	Ø140	1
Ref.no	Part.no	Description	Data	Qty
Date:	29.aug.11	115 202		

SCREW FEEDING SYSTEM

GS15 - GS20

15 - 8 - 2011

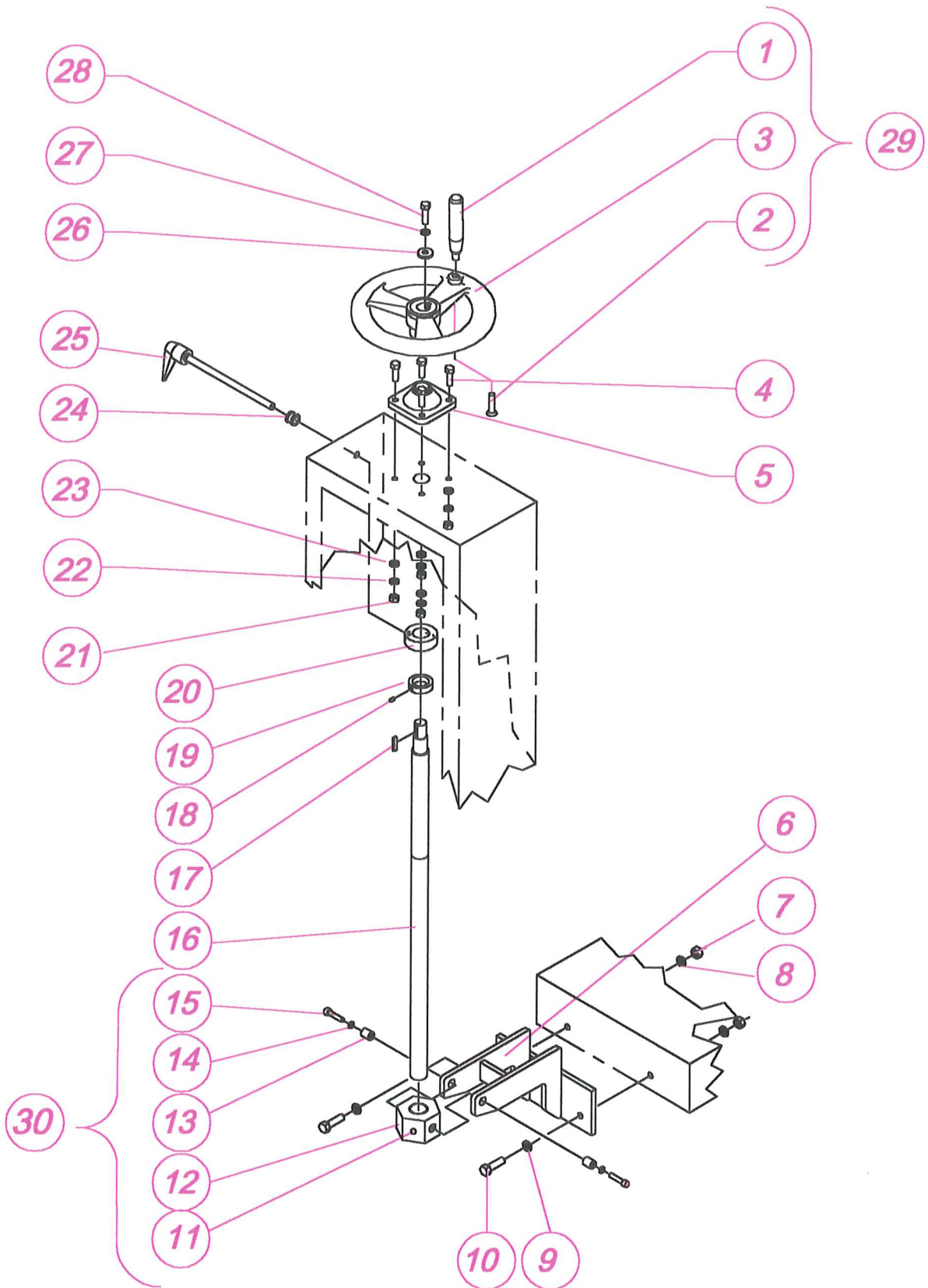



Screw feeding system

GS15 GS20

115 203

Ref.no	Part.no	Description	Data	Qty
1	810 023	Handle		1
2	850 039	Screw, hexagonale socket	M6x20	1
3	810 018	Screw feeding wheel		1
4	850 010	Screw	M10x30	4
5	810 019	Ball bearing	UCF205	1
6	115 079	Screw feeding bracket		1
7	850 094	Locking nut	M12	2
8	850 048	Washer	M12	2
9	850 048	Washer	M12	2
10	850 019	Screw	M12x40	2
11	850 106	Grease nippel	1/8"R	1
12	115 080	Screw feeding nut		1
13	115 758	Distance sleeve		2
14	850 054	Spring washer	M8	2
15	850 040	Screw hexagonale socket	M8x30	2
16	115 081	Screw feeding spindel		1
17	115 085	Key	6x6x25	1
18	850 031	Set screw, hexagonale socket	M6x8	1
19	115 084	Locking ring		1
20	115 083	Stop ring		1
21	850 075	Nut	M10	4
22	850 055	Spring washer	M10	4
23	850 047	Washer	M10	4
24	810 021	Rubber seal	13x21x26	1
25	115 813	Locking brass screw with handle	L=210	1
26	850 108	Washer	M10x30x4	1
27	850 055	Spring washer	M10x30x4	1
28	850 011	Screw	M10x35	1
29	311 104 00	Screw feeding wheel complete		1
30	311 107 00	Screw feeding nut complete		1
Ref.no	Part.no	Description	Data	Qty
Date:	24.aug.11	115 203		

BLADE SHAFT

GS15 - GS20

15-8-2011

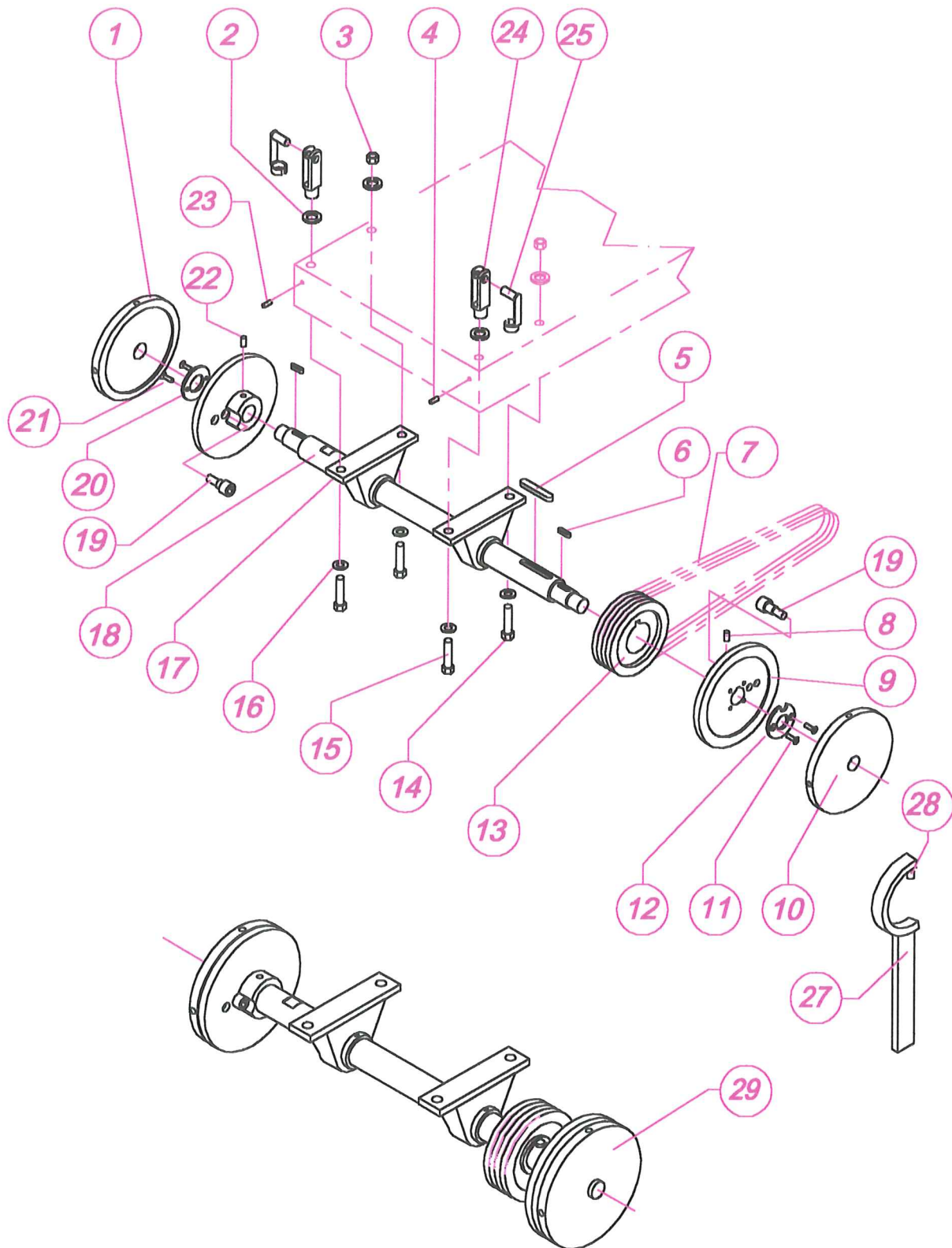



Blade shaft

GS15 GS20

115 859

Ref.no	Part.no	Description	Data	Qty
1	115 789	Blade flange, left thread, right side	Ø140	1
2	850 056	Spring washer	M12	4
3	850 076	Nut	M12	2
4	850 041	Set screw, hexagonale socket	M8x12	1
5	115 180	Key	12x8x70	1
6	115 085	Key	6x6x25	1
7	810 060	V-belt	XPA 1107 LW	4
8	115 085	Key	6x6x25	1
9	115 856	Inner blade flange		2
10	115 792	Blade flange, right thread, left side	Ø140	1
11	850 060	Screw, hexagonale socket, counters	M6x20	2
12	115 853	Diastane washer (115 090)	Ø60/25,4	1
13	810 059	Pulley for taperlock	SPA132x4	1
14	850 023	Screw	M12x60	2
15	850 021	Screw	M12x50	2
16	850 048	Washer	M12	4
17	810 058	Ball bearing	UCP208	2
18	115 179	Blade shaft	Ø40x685	1
18	115 458	Blade shaft (2012/IE2)	Ø40x735	1
19	115 855	Drive pin	M12	2
20	115 853	Diastane washer	Ø60/25,4	1
21	850 060	Screw, hexagonal socket. Counters	M6x20	2
22	850 041	Set screw, hexagonale socket	M8x12	1
23	850 041	Set screw, hexagonale socket	M8x12	1
24	810 012	ES link	M12x24	2
25	810 011	ES pin	M12x24	2
27	115 184	C wrench	Ø140	1
28	850 102	Slotted spring pin	Ø8x26	1
29	311 190 00	Blade shaft complete Ø140	L=685	1
Ref.no	Part.no	Description	Data	Qty
Date:	22.mar.12	115 859	Version:	1

FRONT WHEEL ASSEMBLY

GS15 - GS20

15-8-2011

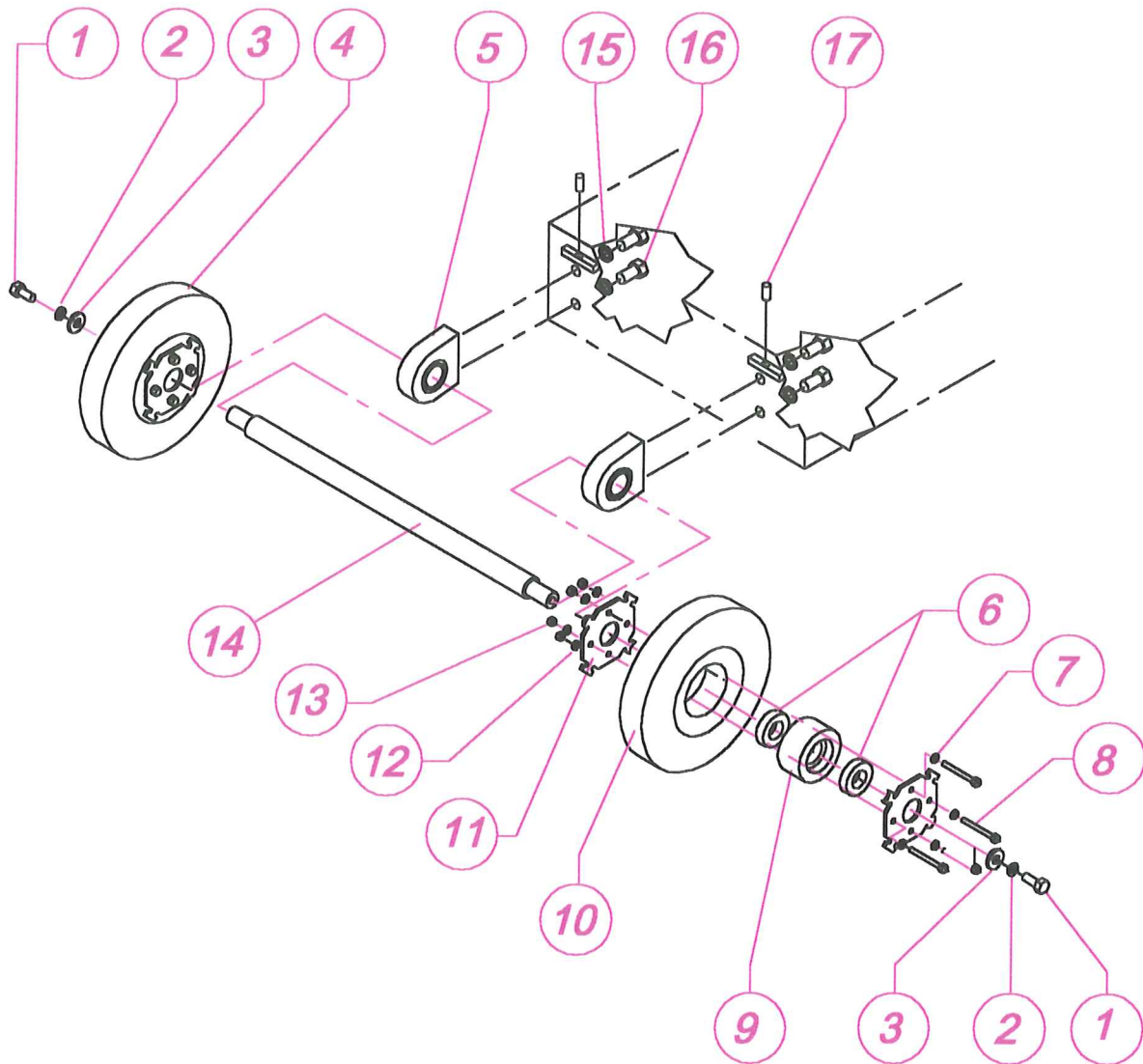



Front wheel assembly

GS15 GS20

115 205

Ref.no	Part.no	Description	Data	Qty
1	850 009	Screw	M10x25	2
2	850 055	Spring washer	M10	2
3	850 108	Washer	M10x30x4	2
4	311 105 00	Front wheel complete		2
5	810 052	Ball bearing	UCPA 206	2
6	810 032	Ball bearing	6005 2RS	4
8	850 004	Screw	M6x55	8
9	115 091	Front wheel hub		2
10	810 033	Rubber tire		2
11	115 093	Wheel hub		4
12	850 045	Washer	M6	8
13	850 073	Nut	M6	8
14	115 169	Front wheel axle	Ø30x525	1
15	850 057	Spring washer	M14	4
16	850 026	Screw	M14x25	4
17	850 035	Set screw, hexagonale socket	M8x10	2
	311 113 00	Front wheel assembly complete 525		
Ref.no	Part.no	Description	Data	Qty
Date:	26.aug.11	115 205		

REAR WHEEL ASSEMBLY

GS15 - GS20

15-8-2011

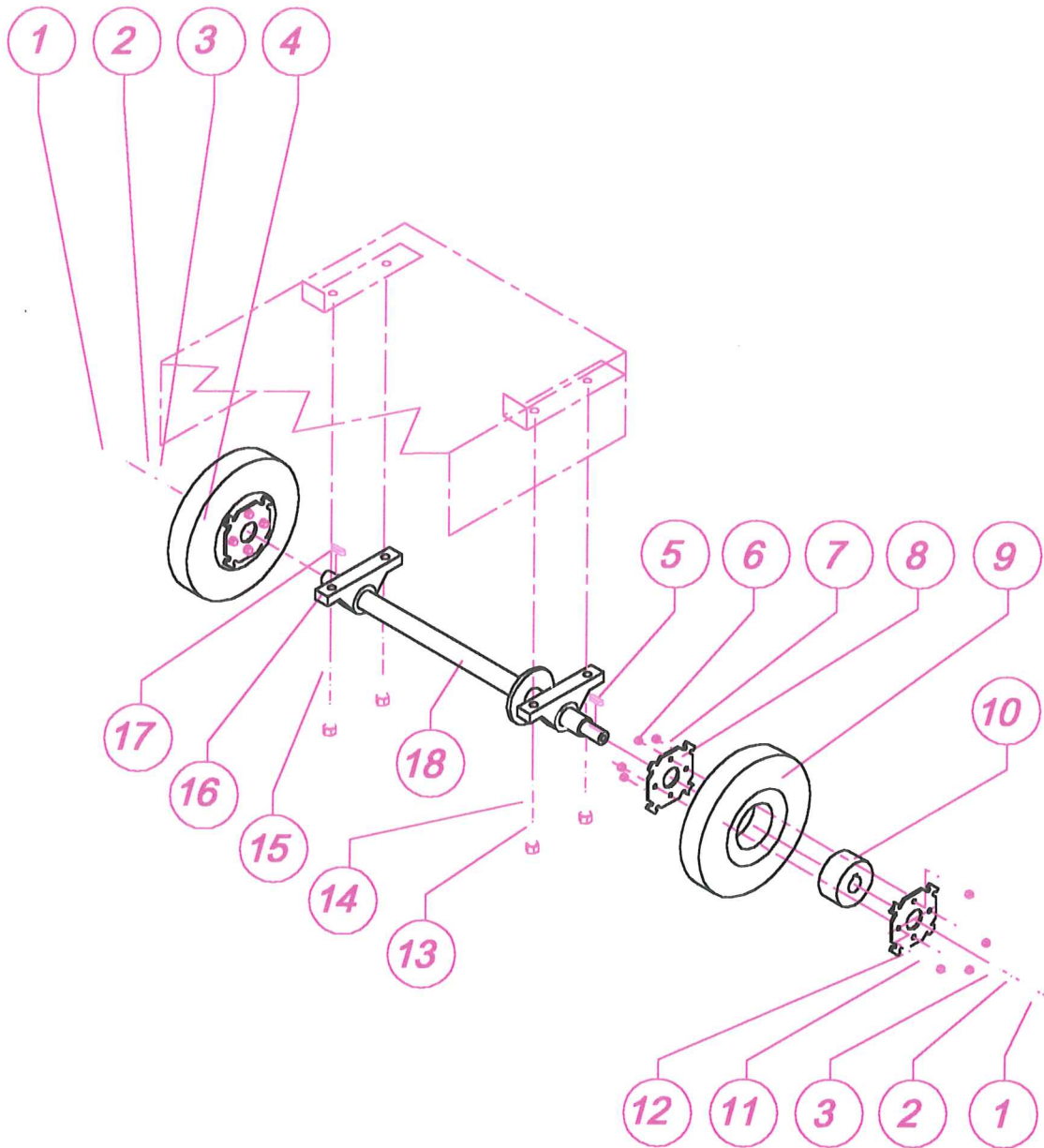



Rear wheel assembly

GS15 GS20

115 206

Ref.no	Part.no	Description	Data	Qty
1	850 009	Screw	M10x25	2
2	850 055	Spring washer	M10	2
3	850 108	Washer	M10x30x4	2
4	311 110 00	Rear wheel complete		2
5	115 085	Key	6x6x25	1
6	850 073	Nut	M6	8
7	850 045	Washer	M6	8
8	115 093	Wheel rim		4
9	810 033	Rubber tire		2
10	115 354	Rear wheel hub		2
11	850 004	Screw	M6x55	8
13	850 018	Screw	M12x35	4
14	850 056	Spring washer	M12	4
15	850 048	Washer	M12	4
16	810 031	Ball bearing	UCP 206	2
17	115 085	Key	6x6x25	1
18	115 171	Rear wheel axle	Ø30x525	1
	311 117 00	Rear wheel axle complete L525		
Ref.no	Part.no	Description	Data	Qty
Date:	29.aug.11	115 206		

FRAME CONNECTION

GS15 - GS20

15 - 8 - 2011

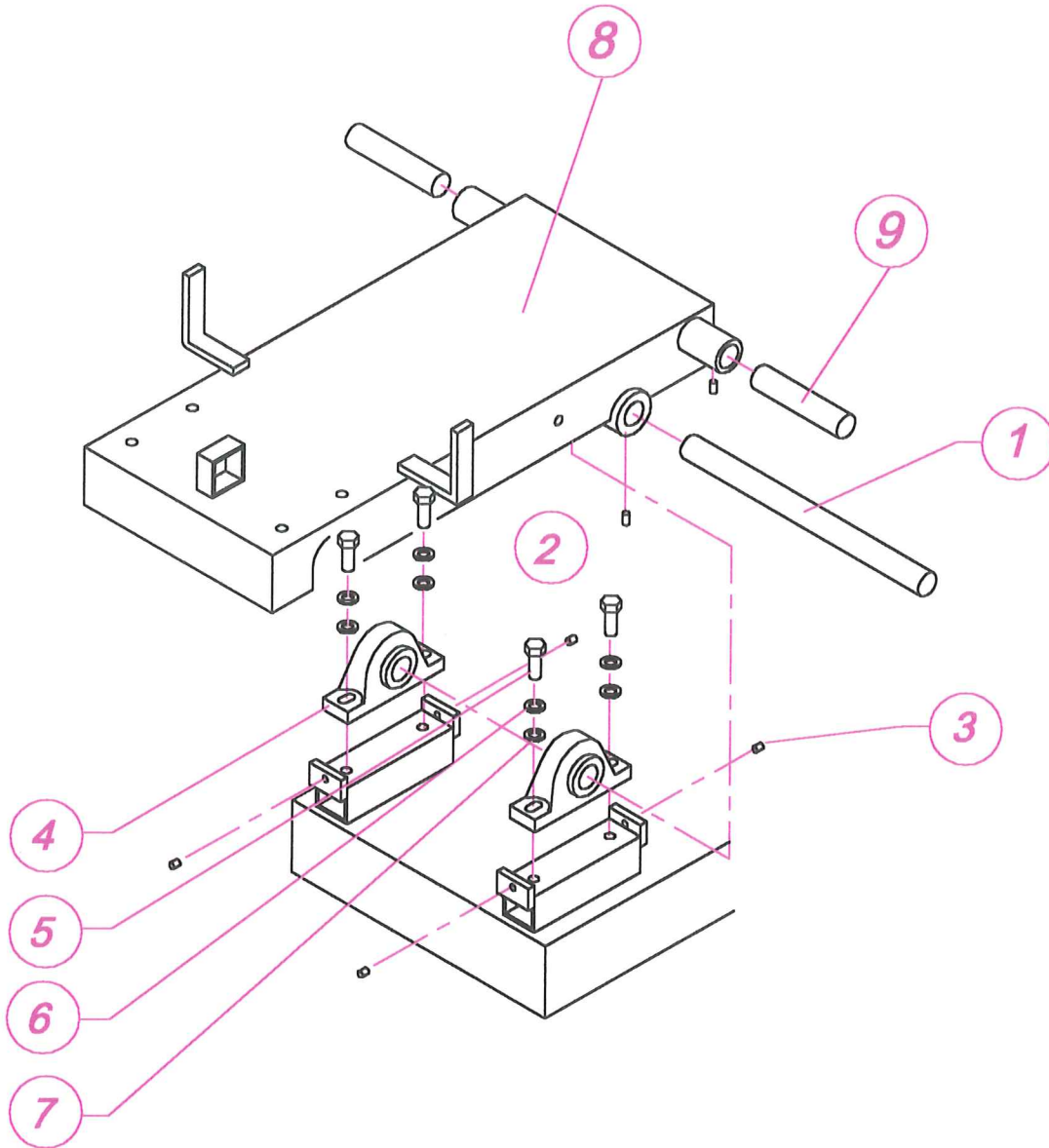



Frame connection

GS15 GS20

115 207

<i>Ref.no</i>	<i>Part.no</i>	<i>Description</i>	<i>Data</i>	<i>Qty</i>
1	115 146	Shaft movable frame	Ø30 L390	1
2	850 035	Set screw, hexagonale socket	M8x10	2
3	850 035	Set screw, hexagonale socket	M8x10	2
4	810 031	Ball bearing	UCP 206	2
5	850 018	Screw	M12x35	4
6	850 056	Spring washer	M12x35	4
7	550 048	Washer	M12	4
8	115 386	Movable frame		1
9	115 335	Shaft for blade - spindel cover	L 170	2
<i>Ref.no</i>	<i>Part.no</i>	<i>Description</i>	<i>Data</i>	<i>Qty</i>
<i>Date:</i>	18.aug.11	115 207		

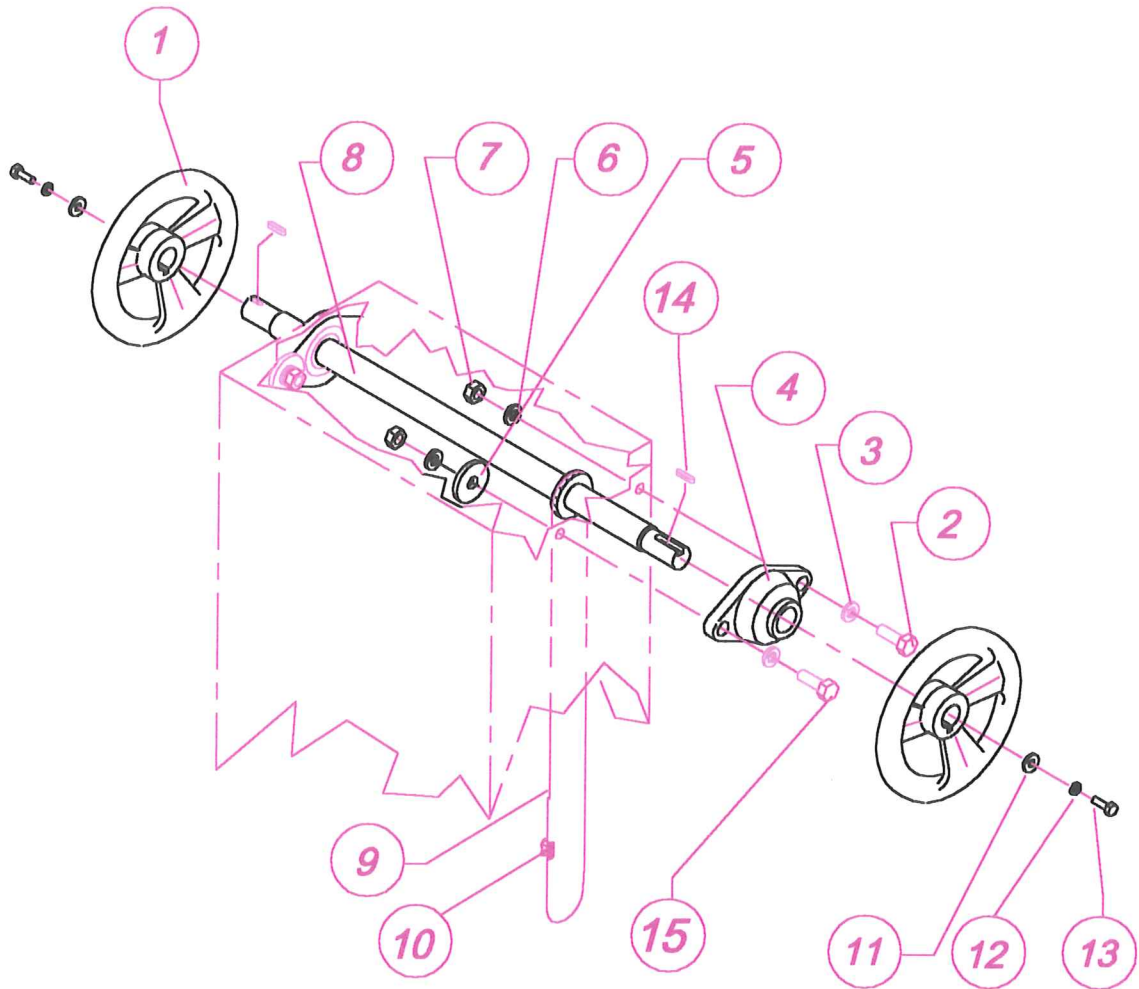



Manual feeding system

GS15 GS20

115 210

	Part.no	Description	Data	Qty
1	810 053	Feeding wheel	Ø370	2
2	850 018	Screw	M12x35	2
3	850 048	Washer	M12	4
4	810 054	Ball bearing	UCFL 205	2
5	850 121	Washer	M13x40x3	2
6	850 056	Spring washer	M12	4
7	850 076	Nut	M12	4
8	115 176	Feeding shaft with sprocket wheel	GS15-20	1
9	311 154 00	Chain complete with lock L1775	3/8" ISO	1
10	810 056	Chain lock	3/8" ISO	1
11	850 108	Washer	M10x30x4	2
12	850 055	Spring washer	M10	2
13	850 009	Screw	M10x25	2
14	115 085	Key	6x6x25	2
15	850 018	Screw	M12x35	2
Ref.no	Part.no	Description	Data	Qty
Date:	29.aug.11	115 210		

Blade guard Ø1000

311 221 00

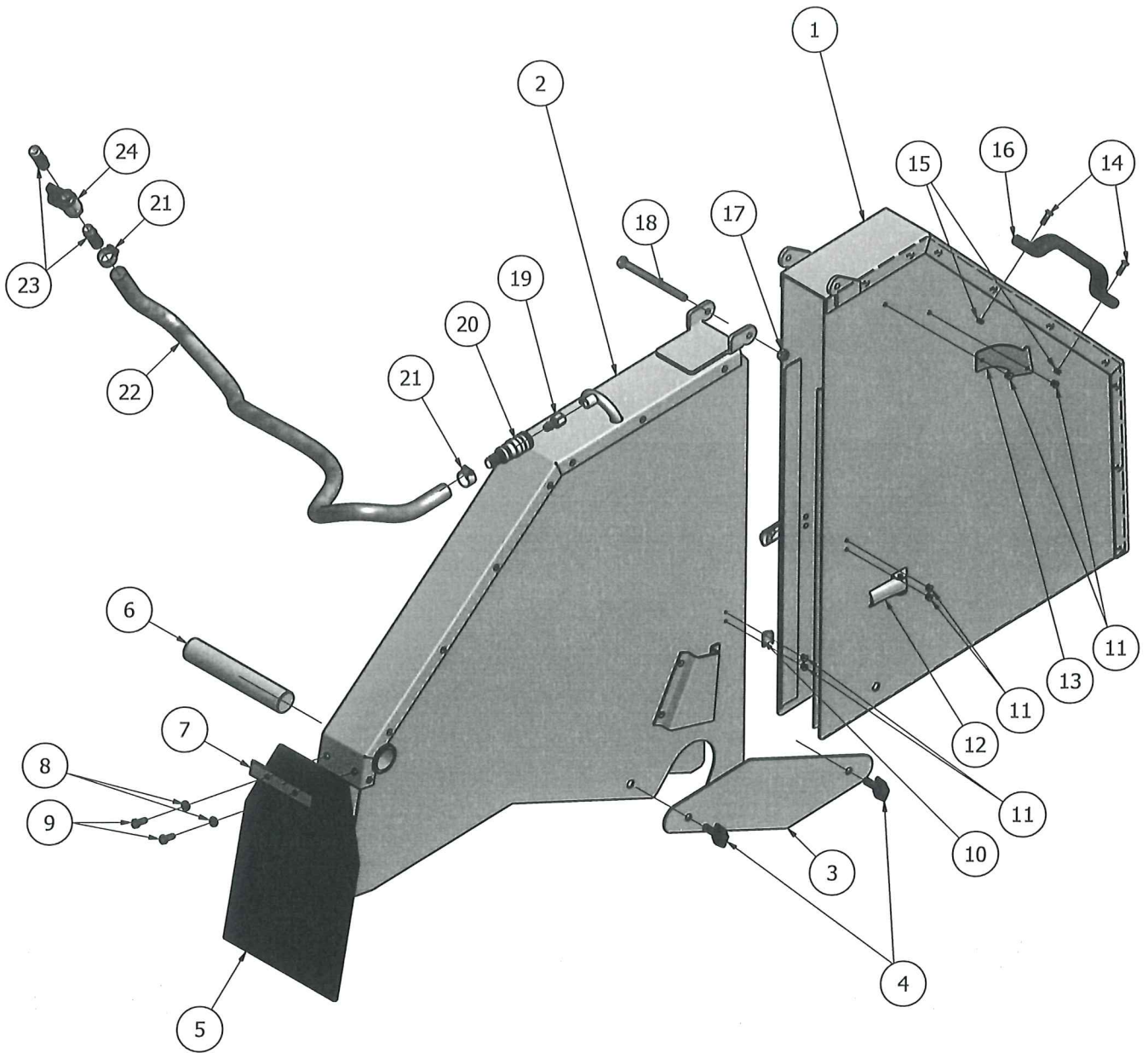

Date	Description	Version
06.01.2012		



Blade Guard complete Ø1000

GS15 - GSA - GXL

311 221 00

Ref.no	Part.no	Description	Data	Qty
1	116 073	Rear blade guard	Ø1200	1
2	116 072	Front blade guard	Ø1200	1
3	116 076	Protection for balde guard		1
4	810 541	Wing screw	M8	2
5	115 057	Rubber guard		1
6	115 163	Connection pin blade guard	Ø30	1
7	115 097	Bracket		1
8	850 045	Spring washer	M6	2
9	850 002	Screw	M6x16	2
10	850 148	Eksenter lock bend		2
11	850 103	Pop nut	4,8x10	12
12	850 147	Ekseneter lock		2
13	116 120	Rotation arrow		2
14	850 143	Screw	M5x12	2
15	850 090	Locing nut	M5	2
16	850 149	Handle		1
17	850 092	Nuts	M8	1
18	850 141	Screw	M8x110	1
19	850 145	Water coupling	CEJN 320	1
20	810 538	Hose conection	CEJN 320	1
21	810 572	Hose clamp	1/2"	2
22	810 044	Hose	1/2"	1
23	810 539	Hose conector	1/2"	2
24	810 540	Water tap	1/2"	1
Ref.no	Part.no	Description	Data	Qty
Date:	06.jan.12		Version:	1

COVER ASSEMBLY

GS15 GS20

15.08.2011

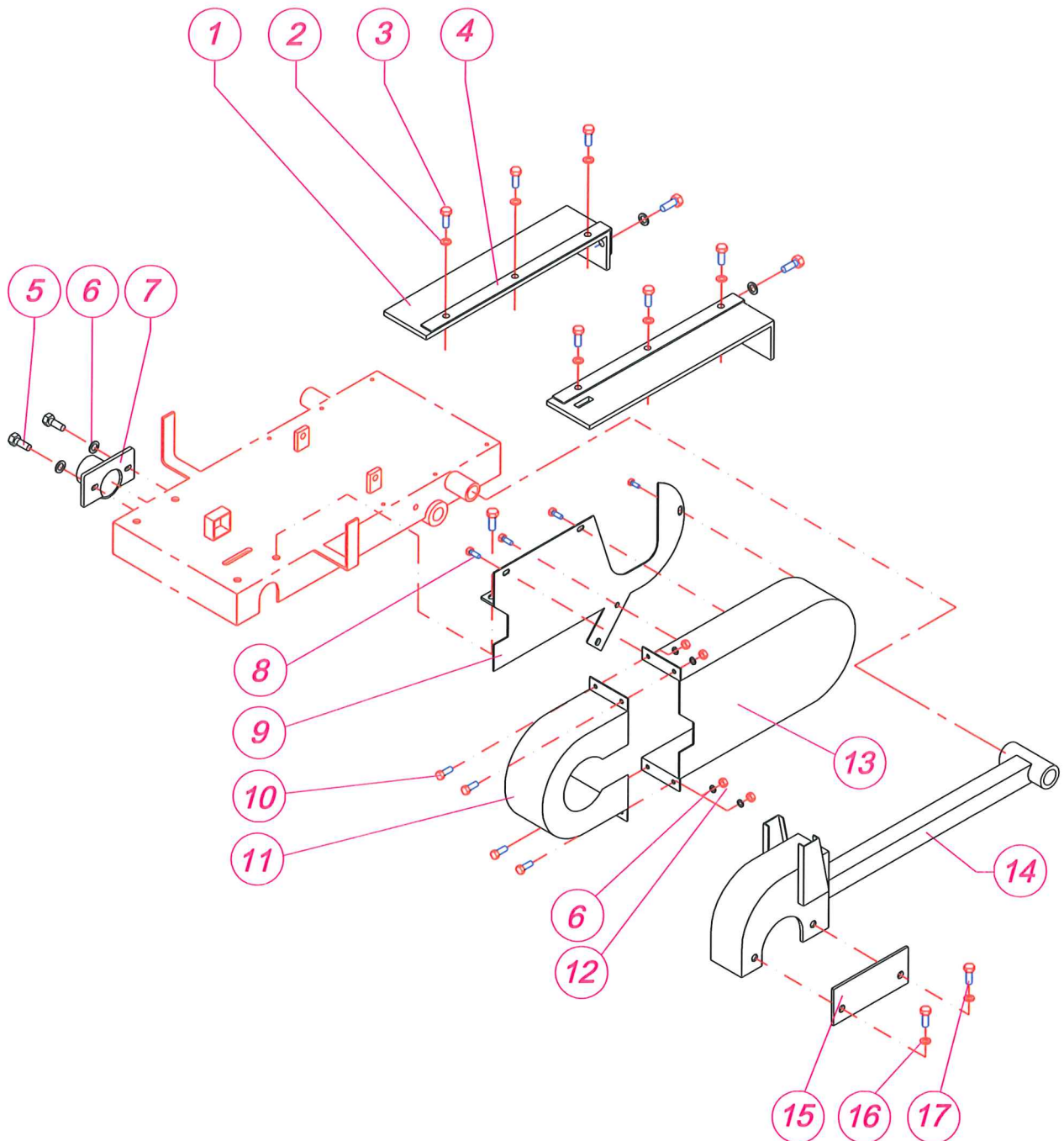



Cover Assembly

GS15 GS20

115 893

<i>Ref.no</i>	<i>Part.no</i>	<i>Description</i>	<i>Data</i>	<i>Qty</i>
1	115 161	Rubber splash		2
2	850 053	Spring washer	M6	8
3	850 002	Screw	M6x16	8
4	115 162	Bracket for rubber splash		2
5	850 002	Screw	M6 x16	2
6	850 053	Spring washer	M6	1
7	115 769	Protection blade shaft		1
8	850 007	Screw	M8x30	1
9	115 851	V belt protection plate		1
10	850 002	Screw	M6x16	4
11	115 826	Rear V - belt cover		1
12	850 073	Nut	M6	4
13	115 852	Upper V-belt cover		1
14	115 756	Spindel cover protection		1
15	115 841	Cover protection plate		
16	850 053	Spring washer	M6	2
17	850 002	Screw	M6x16	2
<i>Ref.no</i>	<i>Part.no</i>	<i>Description</i>	<i>Data</i>	<i>Qty</i>
<i>Date:</i>	18.aug.11	115 893		

MOTOR CONNECTION

GS15 GS20

06 - 09 - 2011

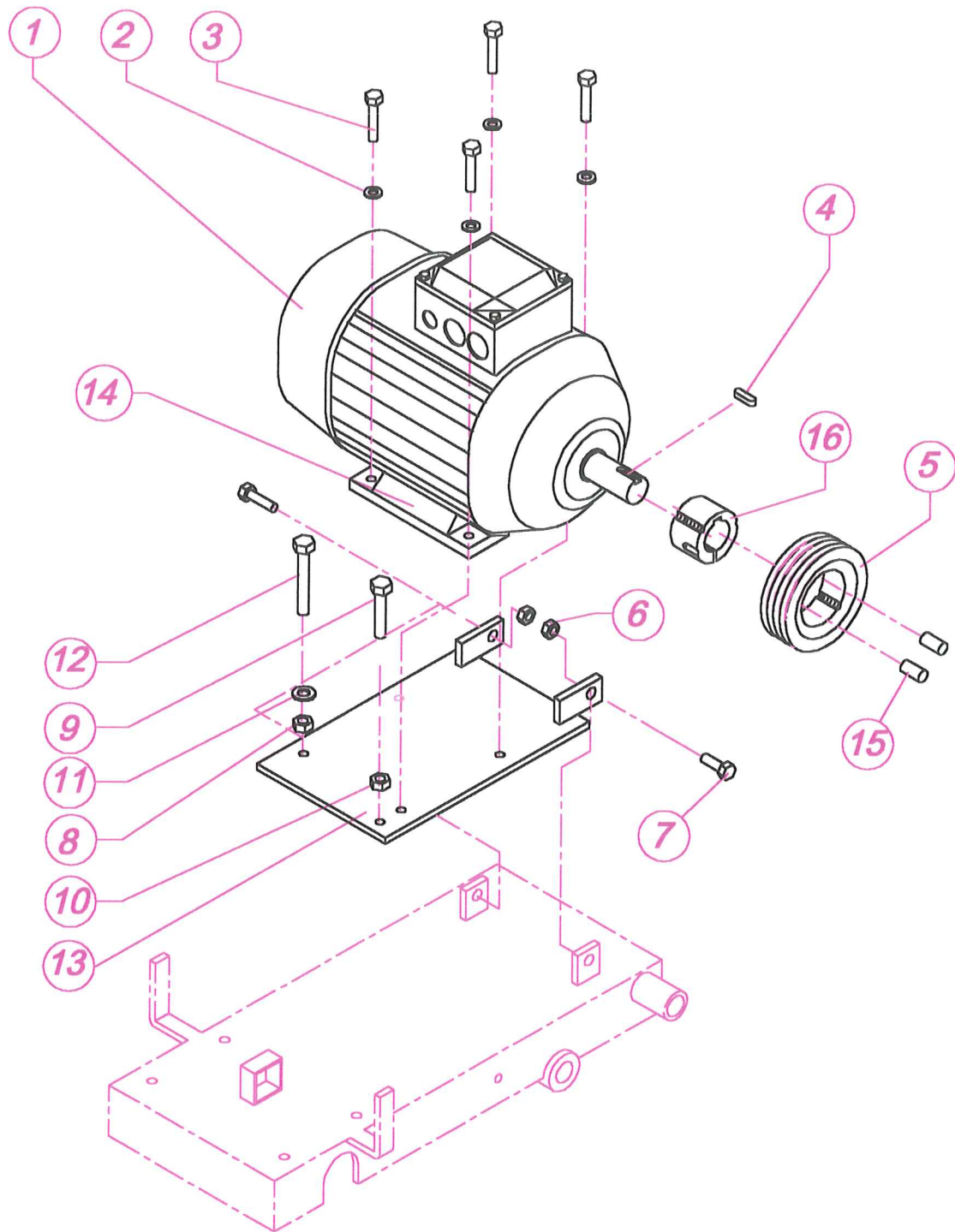



Motor Connection

GS15 GS20

115 211

Ref.no	Part.no	Description	Data	Qty
1		<i>Motor - See electric system</i>		
2	850 056	<i>Spring washer</i>	M12	4
3	850 017	<i>Screw</i>	M12x30	4
4	810 051	<i>Key</i>	12x10x40	1
5	810 128	<i>Pulley</i>	SPA 106x4	1
6	850 094	<i>Locking nut</i>	M12	2
7	850 018	<i>Screw</i>	M12x35	2
8	850 077	<i>Nut</i>	M14	1
9	850 037	<i>Screw</i>	M14x70	1
10	850 076	<i>Nut</i>	M12	1
11	115 805	<i>Washer</i>	M13x30x4	1
12	850 024	<i>Screw</i>	M12x70	1
13	115 172	<i>Motor connection plate</i>		1
14	311 150 00	<i>Motor bracket 11Kw motor complete</i>		1
Ref.no	Part.no	Description	Data	Qty
Date:	18.aug.11	115 211		

SAWING GUIDE

GS15 GS20

15 - 8 - 2011

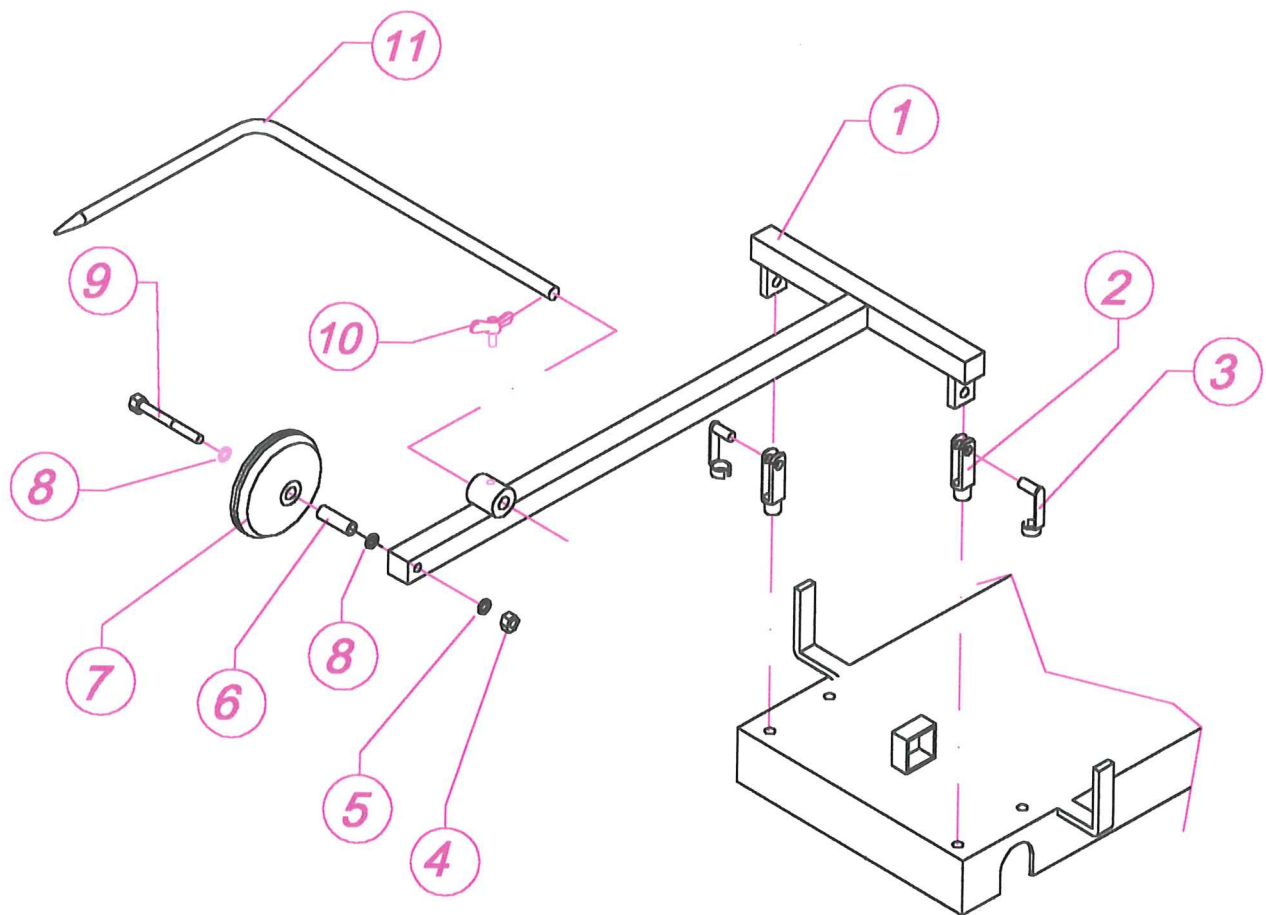



Sawing guide

GS15 GS20

115 212

	<i>Part.no</i>	<i>Description</i>	<i>Data</i>	<i>Qty</i>
<i>1</i>	<i>115 158</i>	<i>Pointer front weldment</i>		<i>1</i>
<i>2</i>	<i>810 012</i>	<i>ES link</i>	<i>M12x24</i>	<i>2</i>
<i>3</i>	<i>810 011</i>	<i>ES pin</i>	<i>M12x24</i>	<i>2</i>
<i>4</i>	<i>850 075</i>	<i>Nut</i>	<i>M10</i>	<i>1</i>
<i>5</i>	<i>850 055</i>	<i>Spring washer</i>	<i>M10</i>	<i>1</i>
<i>6</i>	<i>810 104</i>	<i>Sleeve</i>	<i>Ø15xØ11x46</i>	<i>1</i>
<i>7</i>	<i>810 010</i>	<i>Wheel, sawing guide</i>	<i>Ø125</i>	<i>1</i>
<i>8</i>	<i>850 047</i>	<i>Washer</i>	<i>M10</i>	<i>2</i>
<i>9</i>	<i>850 014</i>	<i>Screw</i>	<i>M10x90</i>	<i>1</i>
<i>10</i>	<i>850 084</i>	<i>Wing screw</i>	<i>M8</i>	<i>1</i>
<i>11</i>	<i>115 063</i>	<i>Pointer</i>	<i>Ø12</i>	<i>1</i>
	<i>311 106 00</i>	<i>Complete sawing guide</i>		<i>1</i>
<i>Ref.no</i>	<i>Part.no</i>	<i>Description</i>	<i>Data</i>	<i>Qty</i>
<i>Date:</i>	<i>29.aug.11</i>	<i>115 212</i>		



Quality and performance - the blue line.



Hummelfjellveien 27
2550 Os I Østerdalen
Telephone +47 62 20 20 60
E mail: post@mekanor.no

