

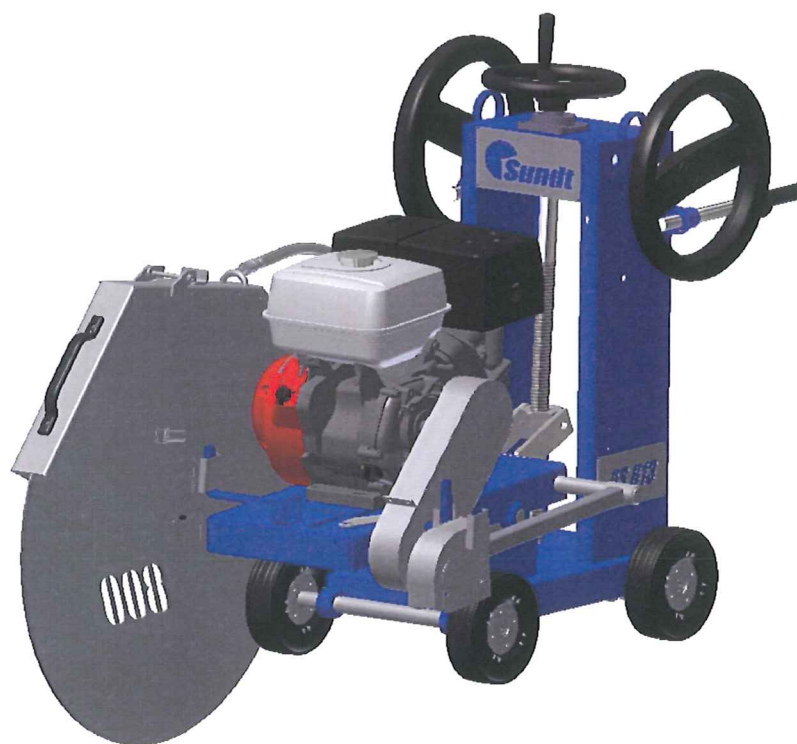

**Reservedeler katalog AS813**  
**Spare part catalogue AS813**  
**Listino ricambi AS813**  
**Ersatzteil Liste AS813**



**MEKANOR**

Hummelfjellveien 27  
2550 Os - Østerdalen  
Phone +47 62 20 20 60





**Quality and performance - the blue line.**

**MEKANOR**

Hummelfjellveien 27  
2550 Os I Østerdalen  
Telephone +47 62 20 20 60  
E mail: [post@mekanor.no](mailto:post@mekanor.no)



# *HONDA GX 390 LX*

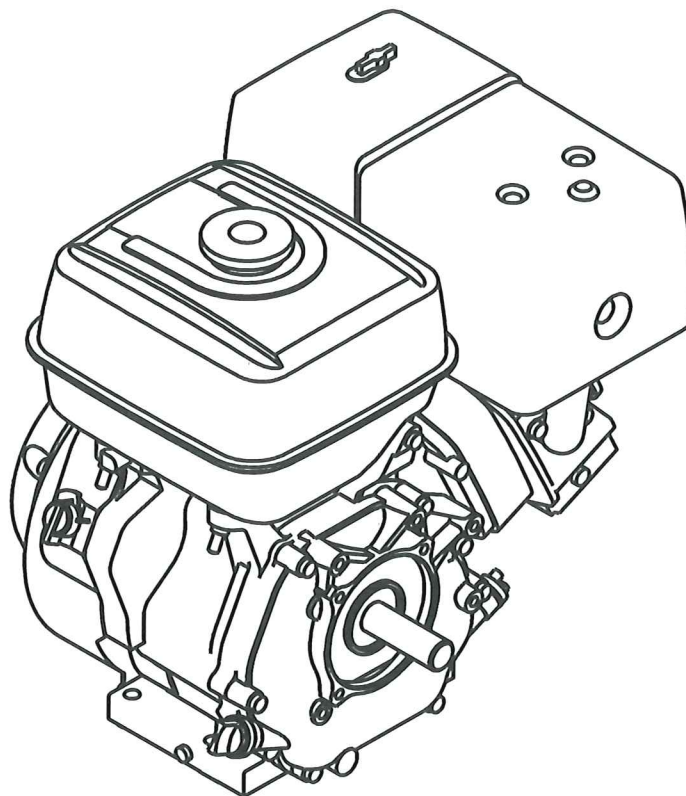

<i>Part.no</i>	<i>Data</i>	<i>Type</i>
810 121	<i>Honda fuel engine</i>	<i>GX 390LX</i>

*-See owners manual*

*Do not use gasoline that contains more than 10% ethanol.*

*Do not use gasoline containing methanol  
(methyl or wood alcohol)*

*that does not also contain cosolvents  
and corrosion inhibitors for methanol*

*Never use gasoline containing more than 5% methanol,  
even if it has cosolvents and corrosion inhibitors.*

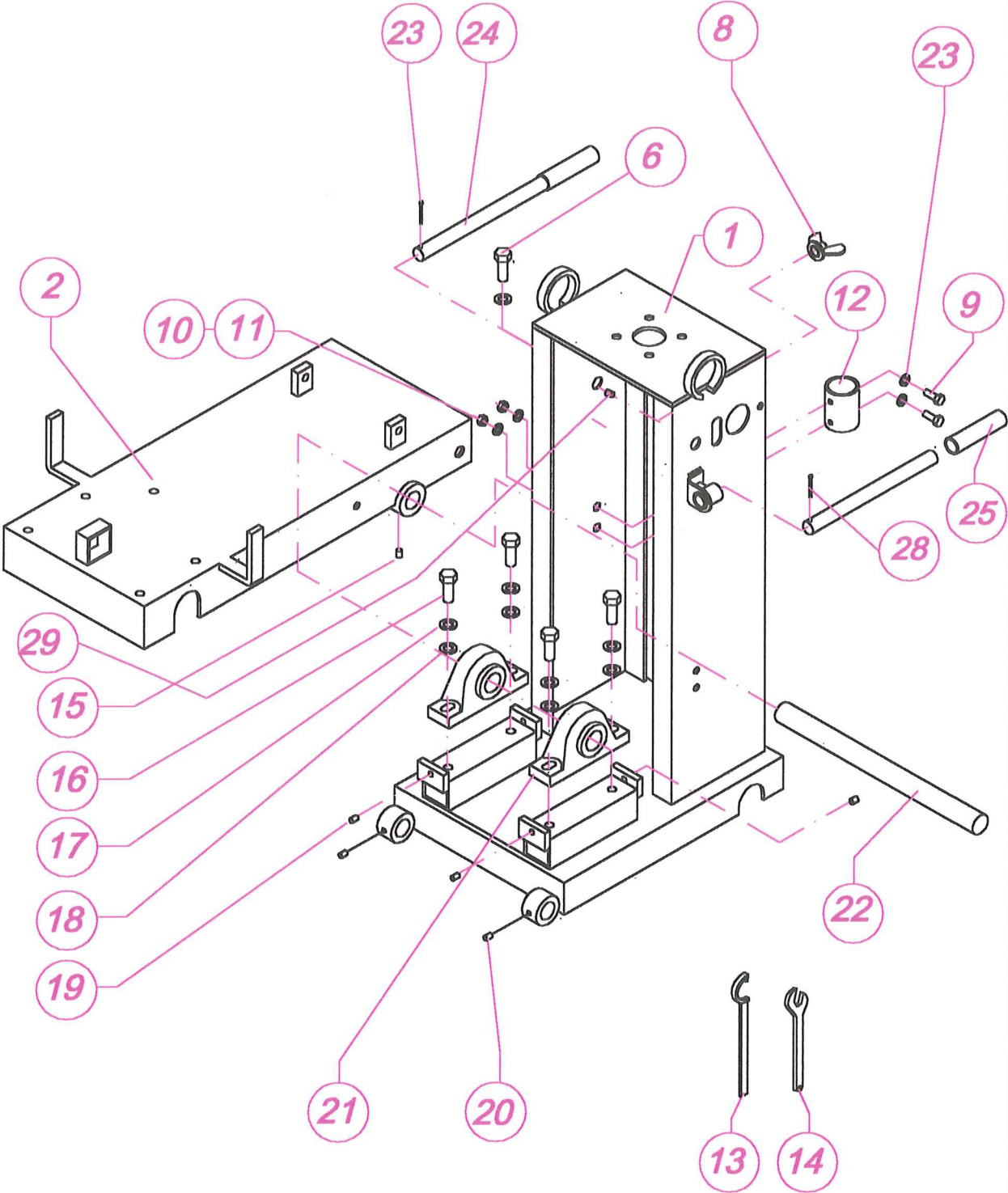





# BASIC FRAME

**GS 800 AS813**

**115 635**

Ref.no	Part.no	Description	Data	Qty
1	115 599	Basic frame	GS800	1
1	116 089	Basic frame	AS813	1
2	115 598	Movable frame	GS800	1
3	850 022	Screw	M12x55	4
5	115 747	Bracket extension handle right side		1
6	850 022	Screw	M12x55	1
8	810 210	Flange holder nut	M12	1
9	850 002	Screw	M6x16	2
10	850 073	Nut	M6	2
11	850 053	Spring washer	M6	2
12	115 048	Tool dispenser	Plastic	1
13	115 595	C-wrench	Ø120	1
14	810 110	Wrensc	32 m.m.	1
15	850 035	Set screw hexagon socket	M8x10	2
16	850 018	Screw	M12x35	4
17	850 056	Spring washer	M12x35	4
18	850 048	Washer	M12x35	4
19	850 035	Set screw, hexagon socket	M8x10	4
20	850 035	Set screw, hexagon socket	M8x10	2
21	810 031	Ball bearing	UCP 206	2
22	115 228	Shaft movable frame	Ø30 L=335	2
23	850 045	Washer	M6	2
24	115 188	Extensioin steering handle with grip	Ø25	2
25	810 001	Handle grip	Rubber	2
26	115 186	Bracket extension handle, left side		1
27	850 027	Wing screw	M8x16	2
28	850 101	Splitt pin	4x32	2
29	115 189	Flange holder sleeve	Ø23	1
<b>Ref.no</b>	<b>Part.no</b>	<b>Description</b>	<b>Data</b>	<b>Qty</b>
Date:	25.okt.11	115 635		

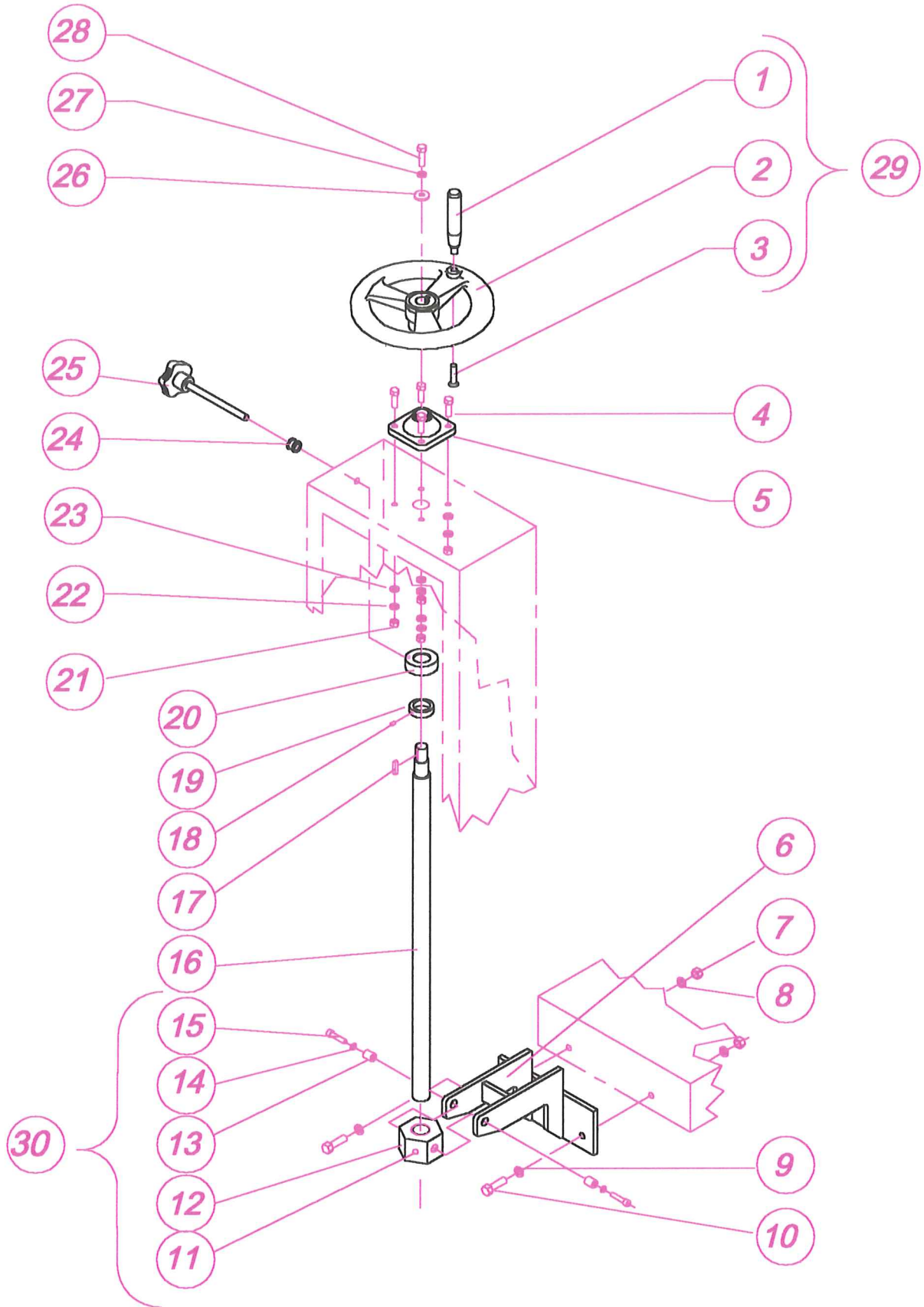



# SCREW FEEDING SYSTEM

**GS800 AS813**

**115 641**

Ref.no	Part.no	Description	Data	Qty
1	810 023	Handle		1
2	810 018	Screw feeding wheel		1
3	850 039	Screw, hexagon socket	M6X20	1
4	850 010	Screw		4
5	810 019	Ball bearing	UCF 205	1
6	115 437	Screw feeding bracket	GS600/GS800	1
7	850 094	Locking nut	M12	2
8	850 048	Washer	M12	2
9	850 048	Washer	M12	2
10	850 019	Srew	M12 x 40	2
11	850 106	Grease nippel	1/8"	1
12	115 080	Srew feeding nut		1
13	115 758	Distance sleeve		2
14	850 054	Spring washer	M8	2
15	850 040	Screw hexagon socket	M8 x 30	2
16	115 081	Screw feeding spindel		1
17	115 085	Key	6 x 6 x25	1
18	850 031	Set screw, hexagon socket	M6x6	1
19	115 084	Locking ring		
20	115 083	Stop ring		1
21	850 075	Nuy	M10	4
22	850 055	Spring washer	M10	4
23	850 047	Washer	M10	4
24	810 021	Rubber seal	13x21x26	1
25	115 812	Locking brass screw with handle	L = 180	1
26	850 108	Washer	M10x30x4	1
27	850 055	Spring washer	M10	1
28	850 011	Screw	M10 x 35	1
29	311 104 00	Screw feeding wheel complete		1
30	311 107 00	Screw feeding nut complete		1
31	116 056	Screw feeding spindel Spes edition	L = (130M.M)	1
32		Screw		4
Ref.no	Part.no	Description	Data	Qty
Date:	07.mai.11	115 641		



# BLADE SHAFT

# GS800 - AS813

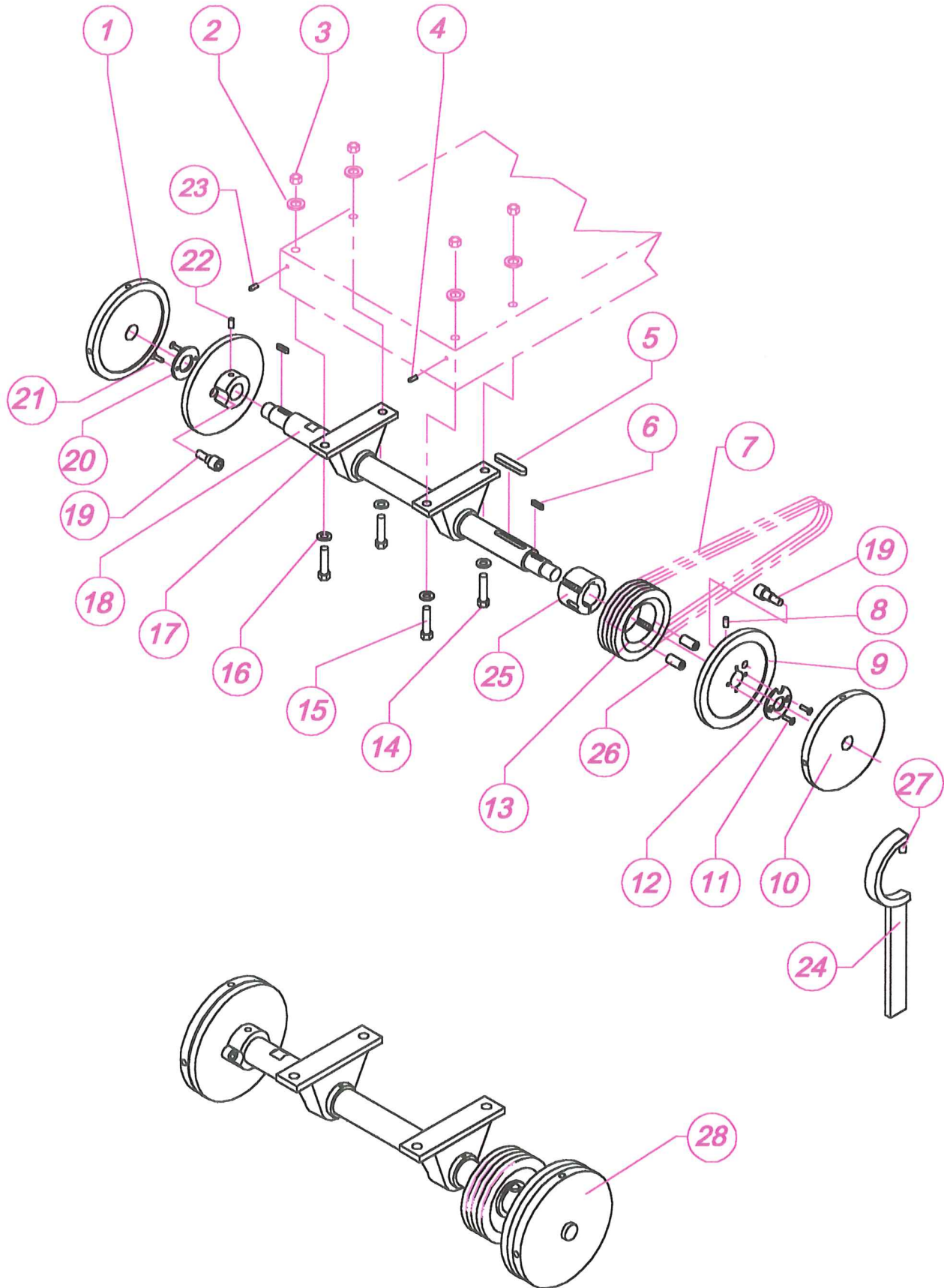





# BLADE SHAFT

**G800 AS813**

**115 858**

Ref.no	Part.no	Description	Data	Qty
1	115 788	Blade flange Left thread, right side	Ø120	1
2	850 056	Spring weasher	M12	4
3	850 076	Nut	M12	4
4	850 041	Set screw, hexagonale socket	M8x12	1
5	115 503	Key	10x8x36	1
6	115 085	Key	6x6x25	2
7	810 153	V belt for GS800 series	XPZ 875 LV	4
7	810 550	V belt for AS813	XPZ900	4
8	850 041	Set screw, hexagonale socket	M8x12	1
9	115 857	Inner blade flange	Ø120	2
10	115 791	Blade flange. Right tread, Left side	Ø120	1
11	850 060	Set screw, hexagonale socket	M6x20	2
12	115 853	Distance washer	Ø60/25,4	2
13	810 151	Pulley for taperlock	SPZ 106x4	1
13	810 548	Pulley for taperlock AS813	SPZ 112/4	1
14	850 020	Screw	M12x45	3
15	850 022	Screw	M12x55	1
16	850 048	Washer	M12	
17	810 109	Ball bearing	UCP 207	2
18	115 215	Blade shaft	Ø35x810	1
19	115 855	Drive pin	M12	4
20	115 853	Distance washer	Ø60x25,4	1
21	850 060	Screw, hexagonal socket counters	M6x20	2
22	850 041	Set screw, hexagonale socket	M2x12	1
23	850 041	Set screw, hexagonale socket	M2x12	1
24	115 595	C wrench	Ø120	1
25	810 048	Taperlock bush	1610x35	1
26	850 113	Set screw, hexagonale socket UNC 3/8"x5/8"		2
27	850 102	Slotted spring pin	Ø8x25	1
28	311 189 00	Blade shaft complete GS800		1
Ref.no	Part.no	Description	Data	Qty
Date:	28.okt.11	115 858		

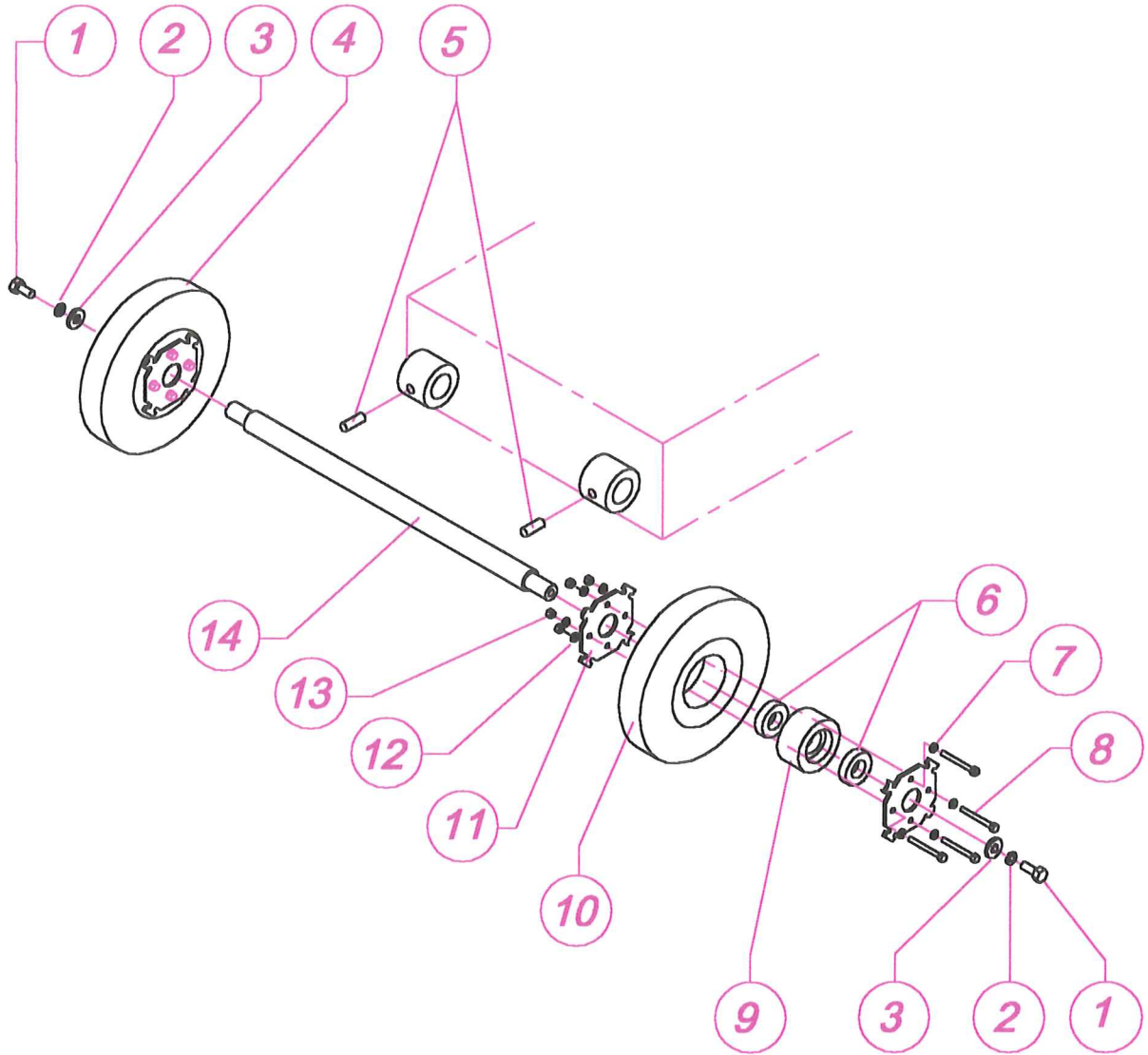

**FRONT WHEEL ASSEMBLY****GS800 AS813****115 637**

<i>Ref.no</i>	<i>Part.no</i>	<i>Description</i>	<i>Data</i>	<i>Qty</i>
1	850 009	Screw	M10x25	2
2	850 055	Spring washer	M10	2
3	850 108	Washer	M10x30x4	2
4	311 105 00	Front wheel complete		2
5	850 035	Set screw hexagonale socket	M8x10	2
6	810 032	Ball bearing	6005 2RS	4
8	850 004	Screw	M6x55	8
9	115 091	Front wheel hub		2
10	810 033	Rubber tire		2
11	115 093	Wheel rim		8
12	850 045	Washer	M6	8
13	850 073	Nut	M6	8
14	115 092	Front wheel axle	Ø30 x 460	1
<i>Ref.no</i>	<i>Part.no</i>	<i>Description</i>	<i>Data</i>	<i>Qty</i>
Date:	14 may 11	115 637		

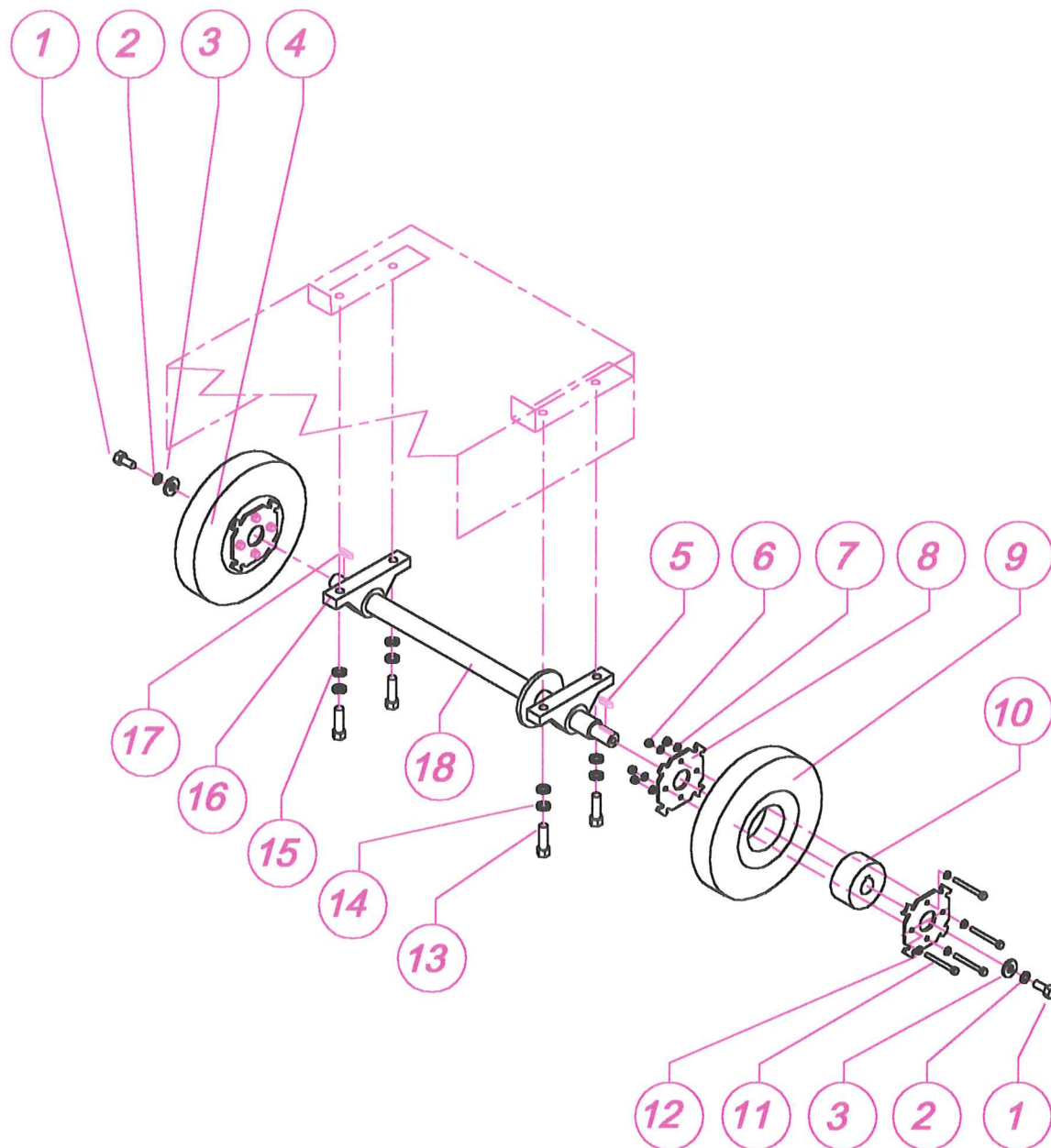



**REAR WHEEL ASSEMBLY****GS800 AS813****115 638**

<i>Ref.no</i>	<i>Part.no</i>	<i>Description</i>	<i>Data</i>	<i>Qty</i>
1	850 009	Screw	M10x25	2
2	850 055	Spring washer	M10	2
3	850 108	Washer	M10x30x4	2
4	311 110 00	Rear wheel complete		2
5	115 085	Key	6x6x25	1
6	850 073	Nut	M6	8
7	850 045	Washer	M6	8
8	115 093	Wheel rim		4
9	810 033	Tubber tire		2
10	115 345	Rear wheel hub		2
11	850 004	Screw	M10x55	8
13	850 018	Screw	M12x35	4
14	850 056	Spring washer	M12	4
15	850 048	Washer	M12	4
16	810 031	Ball bearing	UCP 206	2
17	115 085	Key	6x6x25	1
18	115 608	Rear wheel axle	Ø30x460	1
<i>Ref.no</i>	<i>Part.no</i>	<i>Description</i>	<i>Data</i>	<i>Qty</i>
<i>Date:</i>	12.okt.11	115 638		

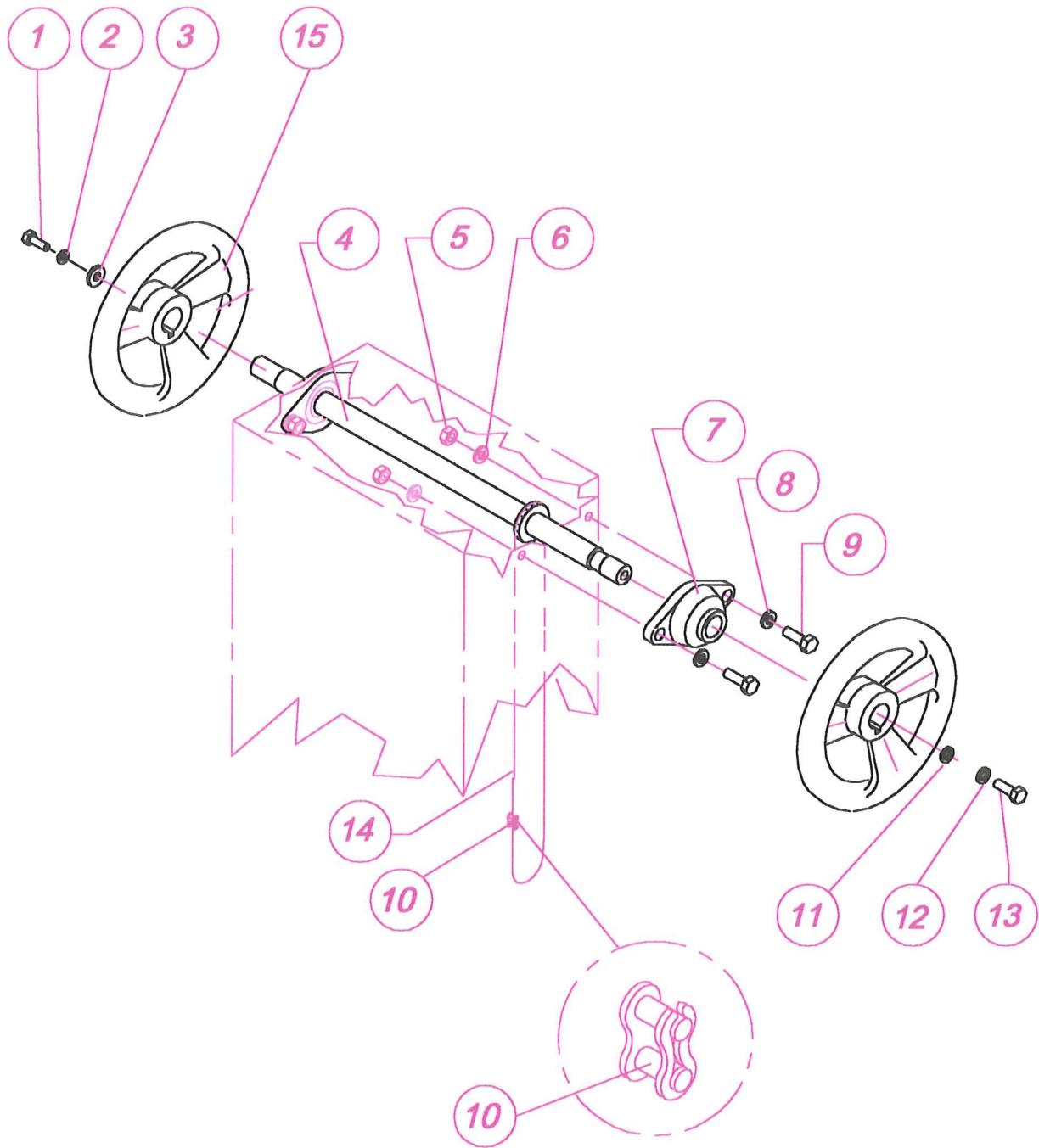



**MANUAL FEEDING SYSTEM**

**GS800 AS813**

**116 055**

<i>Ref.no</i>	<i>Part.no</i>	<i>Description</i>	<i>Data</i>	<i>Qty</i>
1	850 009	Screw	M10 x 25	1
2	850 055	Spring washer	M10 x 25	1
3	850 108	Washer	M10x30x4	1
4	116 058	Feeding shaft with sprocket wheel	Long Combi	1
4	115 612	Feeding shaft with sprocket wheel	Standard	1
5	850 076	Nut	M12	4
6	850 056	Spring washer	M12	4
7	810 054	Ball bearing	UCFL 205	2
8	850 048	Washer	M12	2
9	850 018	Screw	M12 x 35	2
10	810 056	Chain lock	3/8" ISO	1
11	850 108	Spring washer	M10x30x4	1
12	850 055	Spring washer	M10x30x4	1
13	850 009	Screw	M10x25	1
14	311 157 00	Chain complete with lock L1650m.m	3/8" ISO	1
15	810 053	Feeding wheel Ø230	Gamm	2
15	810 537	Feeding wheel Ø375	Elesa	2
16	115 085	Key	6x6x25	2
<i>Ref.no</i>	<i>Part.no</i>	<i>Description</i>	<i>Data</i>	<i>Qty</i>
Date:	26.okt.11	116 055		

# Blade guard Ø800

311 219 00

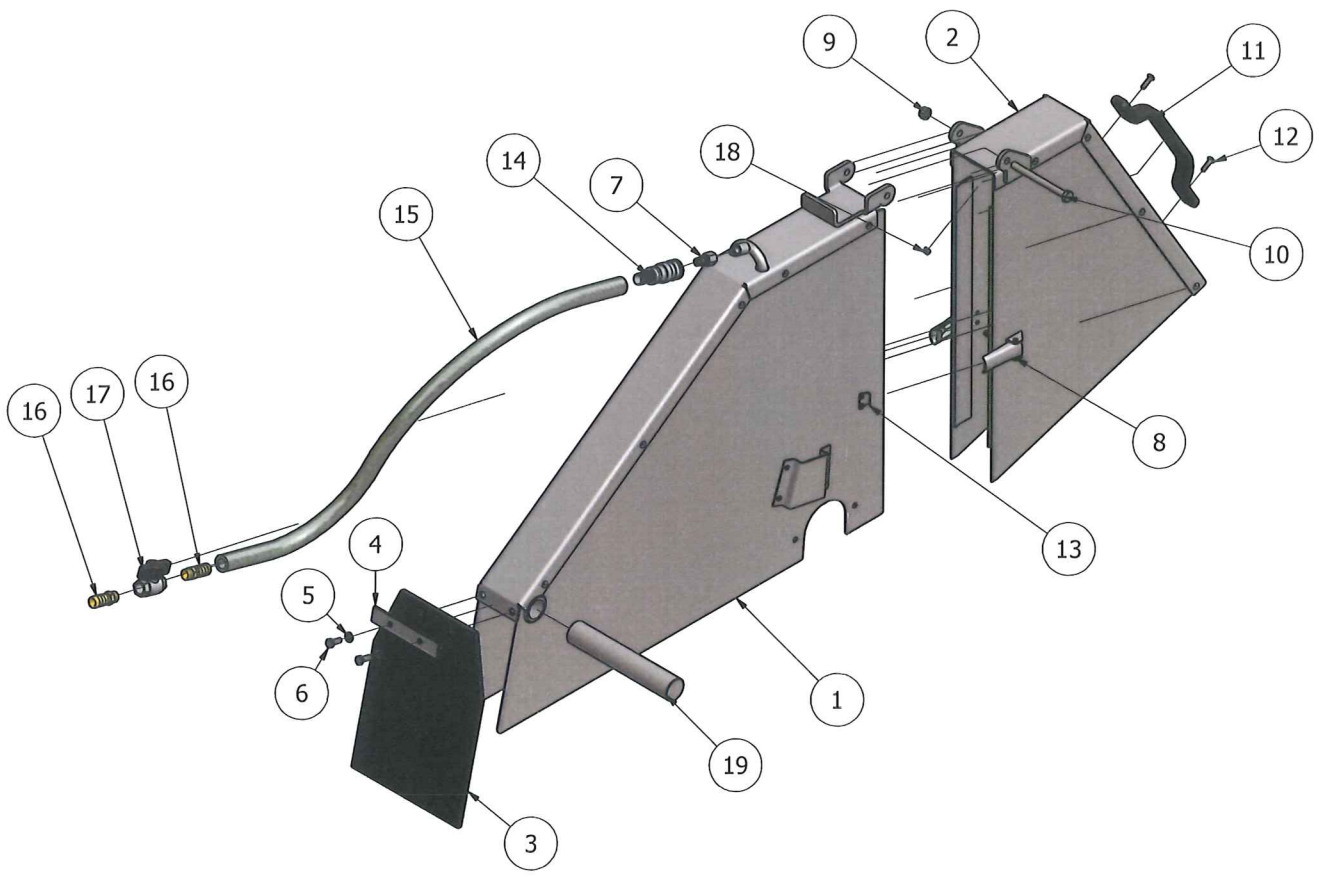



**Blade Guard complete Ø800****GS 800 - AS813****311 219 00**

<i>Ref.no</i>	<i>Part.no</i>	<i>Description</i>	<i>Data</i>	<i>Qty</i>
1	116 052	Rear blade guard	Ø 800	1
2	116 051	Front blade guard	Ø 800	1
3	115 056	Rubber guard		1
4	115 097	Bracket		1
5	850 053	Spring washer	M6	2
6	850 002	Screw	M6x16	2
7	850 145	Water coupling		1
8	850 147	Ekseneter lock		2
9	850 092	Nuts	M8	1
10	850 146	Screw	M8x90	1
11	850 149	Handle		1
12	850 143	Screw	M5x12	2
13	850 148	Eksenter lock bend	CEJN 320	2
14	810 538	Hose conection		
15	810 044	Hose	1/2"	1
16	810 539	Hose conector	1/2"	1
17	810 540	Water tap	1/2"	1
18	850 091	Locking nut	M6	2
<i>Ref.no</i>	<i>Part.no</i>	<i>Description</i>	<i>Data</i>	<i>Qty</i>
<i>Date:</i>	13.okt.11	311 219 00		

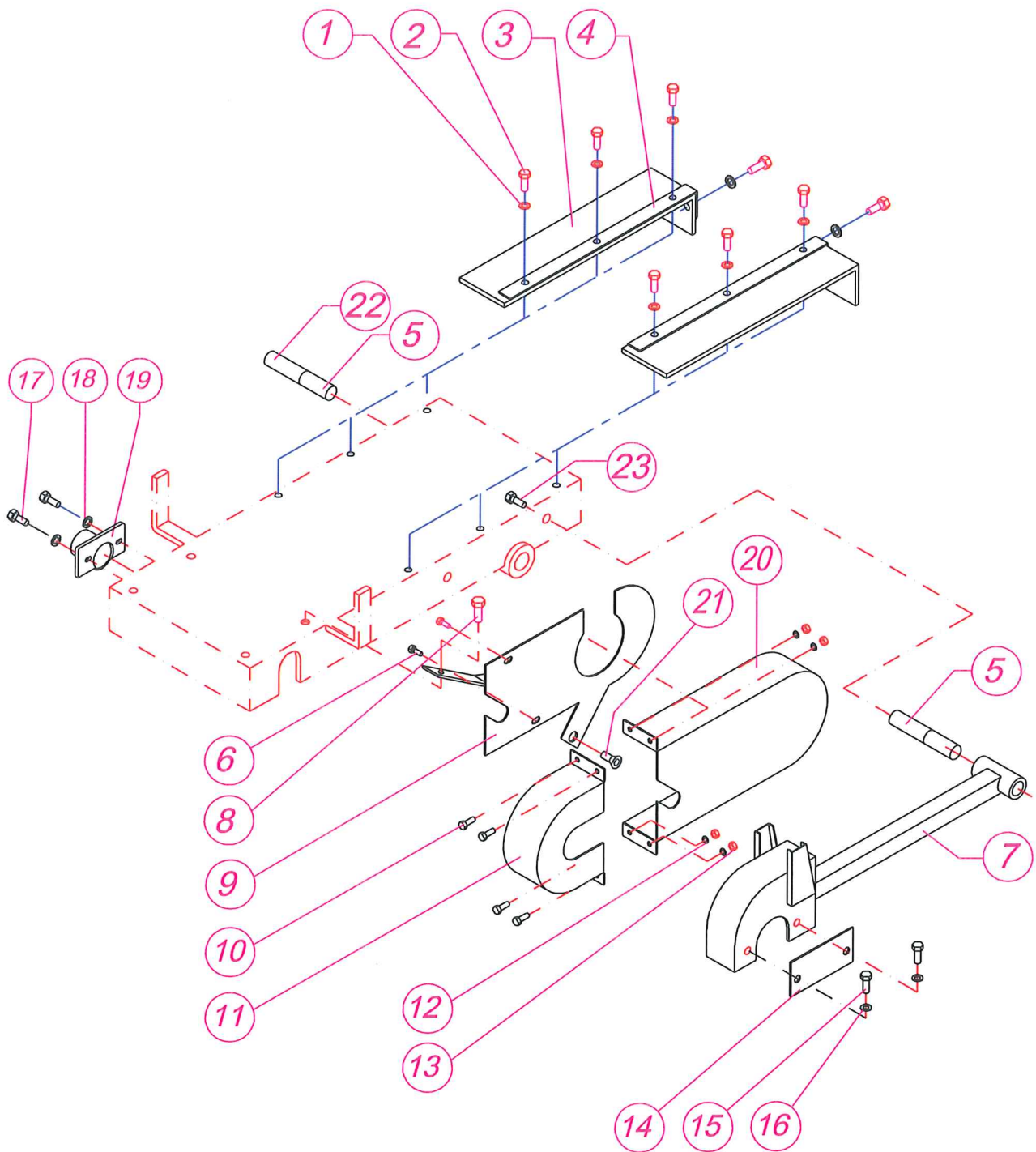



# Cover assembly

**GS800 AS813**

**115 821**

Ref.no	Part.no	Description	Data	Qty
1	850 053	Spring washer	M6	8
2	850 002	Screw	M6 x 16	8
3	115 505	Rubber gard		2
4	115 069	Bracket		2
5	115 335	Connection pin	L=170	2(1 GS811)
6	850 002	Screw	M6 x 16	1
7	115 607	Blade shaft cover		1
8	850 016	Screw	M12 x 25	1
9	115 800	Cover		1
10	850 002	Screw	M6 x 16	4
11	115 823	Front cover (GS800/GS811)		1
11	115 823	Front cover (AS 813)		1
12	850 054	Spring washer	M6	4
12	850 053	Screw	M6 x 16	4
13	850 073	Nut	M6	4
14	115 838	Connection plate		1
15	850 151	Screw	M6 x 8	2
16	850 046	Washer	M8	2
17	850 006	Screw	M6 x 25	2
18	850 054	Washer	M6	2
19	115 764	Shaft protection (GS800/AS813)		1
19	116 179	Shaft protection (GS 811)		1
20	115 824	Rear cover (GS 800/GS811)		1
20	116 181	Rear cover (AS813)		1
21	850 152	Screw confit - hexagon socket	M12x35	1
22	116 182	Connection pin (GS 811)	L=220	1
23	850 017	Screw	M12x30	2
<b>Ref.no</b>	<b>Part.no</b>	<b>Description</b>	<b>Data</b>	<b>Qty</b>
<b>Date:</b>	<b>27.mar.12</b>	<b>115 821</b>	<b>Version:</b>	<b>1</b>

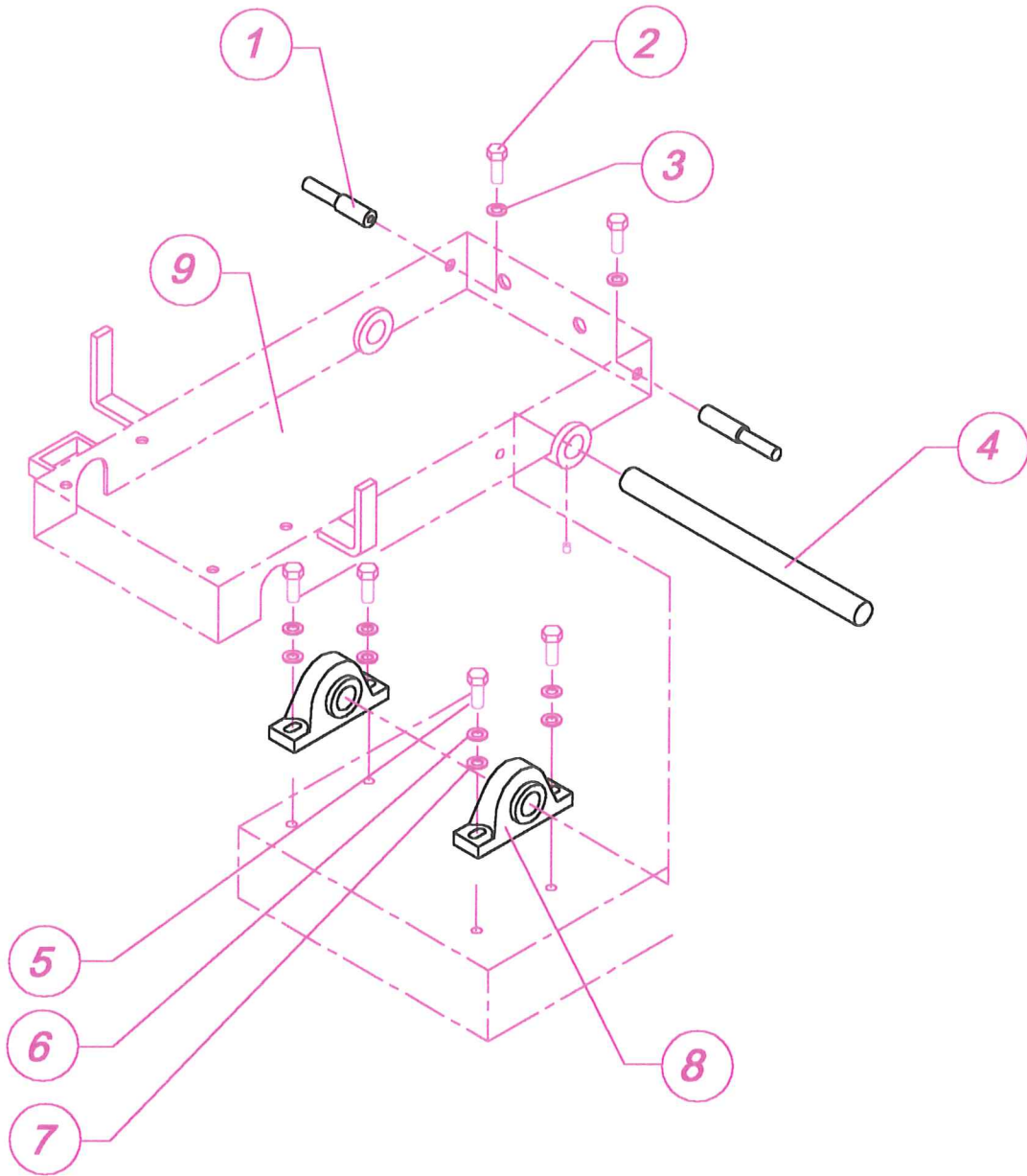





## Frame conection

**GS800 AS813****115 639**

<i>Ref.no</i>	<i>Part.no</i>	<i>Description</i>	<i>Data</i>	<i>Qty</i>
1	115 335	Connection pin	Ø25 x 135	2
2	850 017	Screw	M12 x 30	2
3	850 076	Spring washer	M12	2
4	115 228	Shaft movanle frame	Ø30 L335	1
5	850 019	Screw	M12 x 40	4
6	850 048	Washer	M12	4
7	850 056	Spring washer	M12	4
8	810 031	Ball bearing	UCP 206	2
9	115 598	Movable frame	GS 800	1
<i>Ref.no</i>	<i>Part.no</i>	<i>Description</i>	<i>Data</i>	<i>Qty</i>
<i>Date:</i>	<i>12.okt.11</i>	<i>115 639</i>		

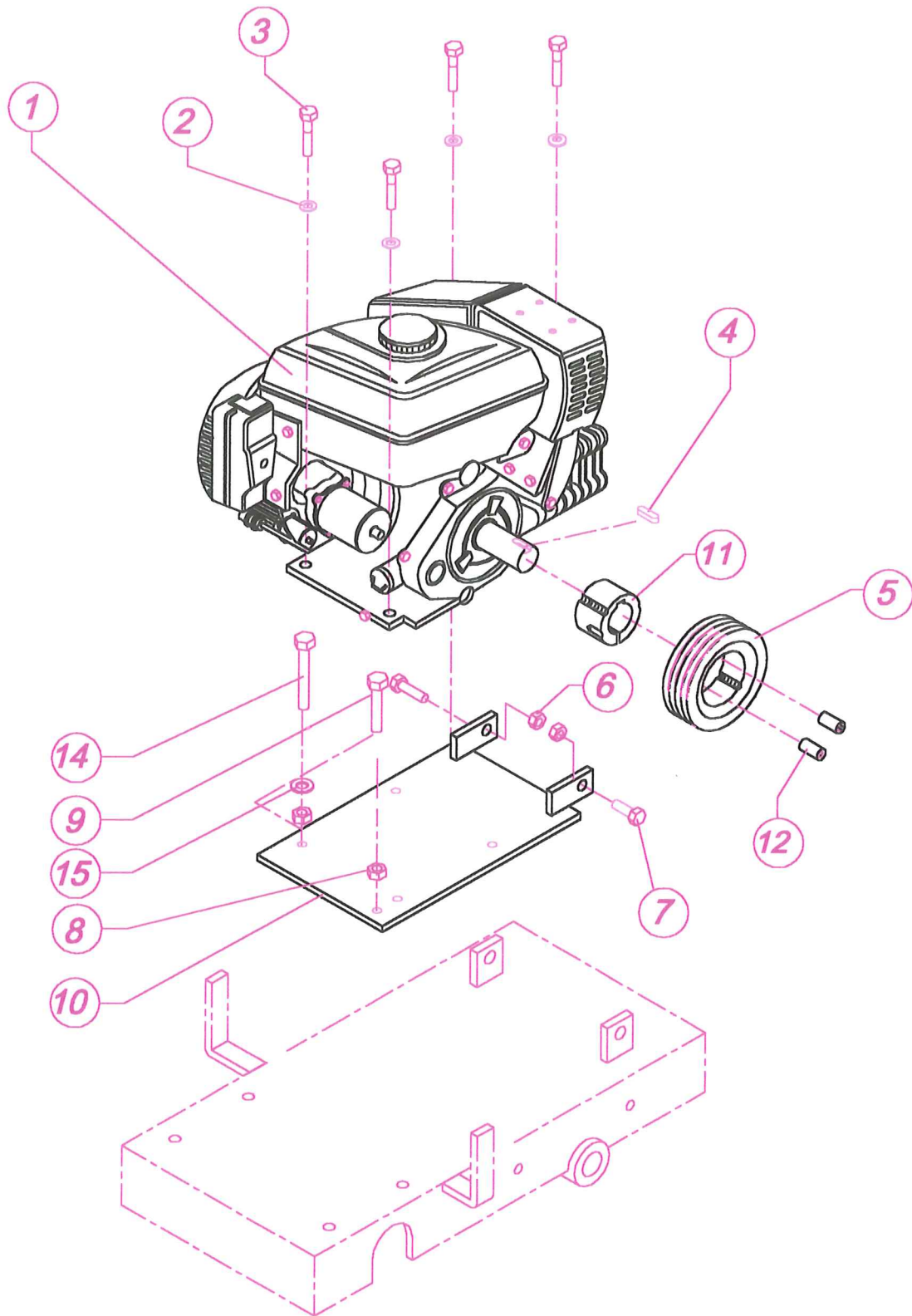



**Motor Connection**

**AS813**

**116 088**

<i>Ref.no</i>	<i>Part.no</i>	<i>Description</i>	<i>Data</i>	<i>Qty</i>
1	810 121	Honda feuel enine 13HP	GX360LX	1
2	850 055	Spring washer	M10	4
3	850 011	Screw	M10x35	4
4	810 023	Key	7x7x30	1
5	810 545	Pulley for taperlock	Ø90 SPZ X 4	1
6	850 076	Nut	M12	2
7	850 017	Screw	M12x30	2
8	850 076	Nut	M12	2
9	850 022	Screw	M12x55	1
10	115 444	Motor connection plate	AS613	1
10	116 093	Motor connection plate	AS813	1
11	810 146	Taper lock bush	1610x25	1
12	850 113	Set screw hexagonale socket	UNC 3/8"x5/8"	2
14	850 063	Screw	M12x80	1
15	115 805	Washer	M13x30x4	1
<i>Ref.no</i>	<i>Part.no</i>	<i>Description</i>	<i>Data</i>	<i>Qty</i>
Date:	25.okt.11	116 088		

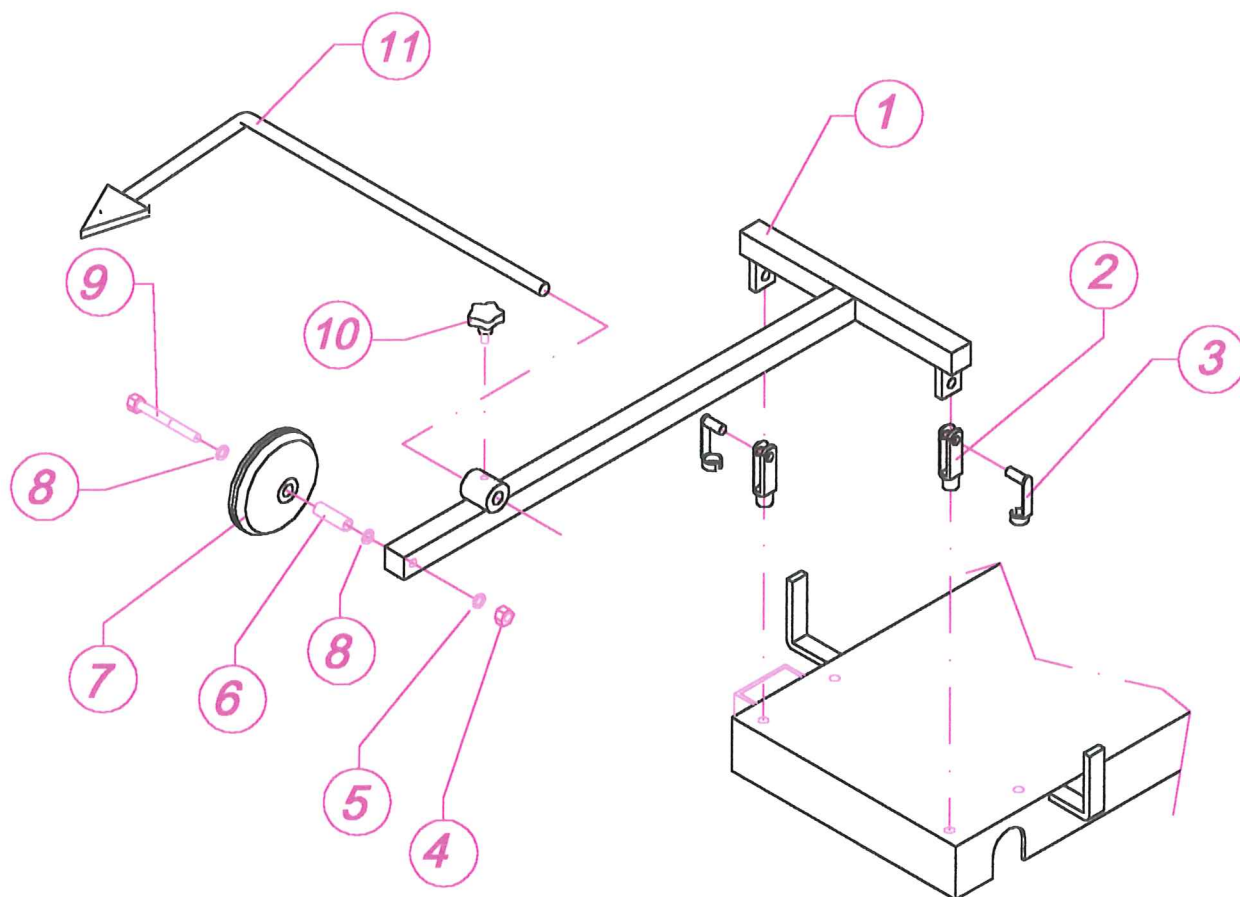





# SAWING GUIDE

**GS800 AS813**

**115 640**

<i>Ref.no</i>	<i>Part.no</i>	<i>Description</i>	<i>Data</i>	<i>Qty</i>
1	115 504	Pointer front weldment		1
2	810 012	ES link	M12 x 24	2
3	810 011	ES pin	M12	2
4	850 075	Nut	M10	1
5	850 055	Spring washer	M10	1
6	810 014	Sleeve	Ø15xØ11x45	1
7	810 010	Wheel sawing guide	Ø125	1
8	850 047	Washer	M10	2
9	850 014	Screw	M10 x 90	1
10	850 084	Wing screw	M8	1
11	115 063	Pointer	Ø12	1
	311 101 00	Complete sawing guide		1
<i>Ref.no</i>	<i>Part.no</i>	<i>Description</i>	<i>Data</i>	<i>Qty</i>
Date:	12.okt.11	115 640		



**Quality and performance - the blue line.**



Hummelfjellveien 27  
2550 Os I Østerdalen  
Telephone +47 62 20 20 60  
E mail: [post@mekanor.no](mailto:post@mekanor.no)

